

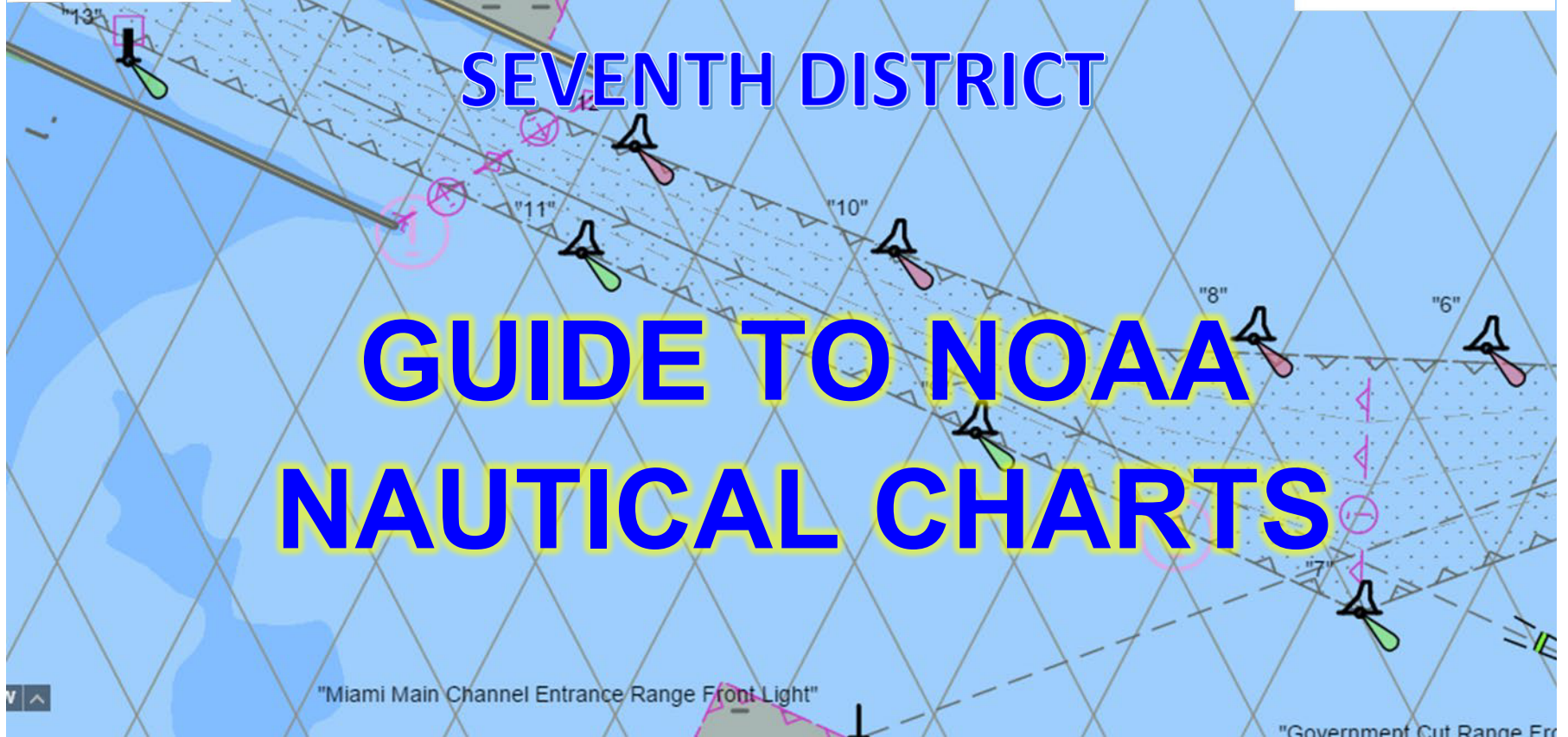

U.S. COAST GUARD AUXILIARY SEVENTH DISTRICT

GUIDE TO NOAA NAUTICAL CHARTS



"Miami Main Channel Entrance Range Front Light"

"Government Cut Range Fr

D7NS 1100.B
SEPTEMBER 2024

U.S.C.G. AUXILIARY SEVENTH DISTRICT NAVIGATION SYSTEMS

**U.S. COAST GUARD AUXILIARY – DISTRICT 7
GUIDE TO NOAA NAUTICAL CHARTS**

CONTENTS

1. Fundamentals of Chart Making	1
2. Chart Projections.....	3
3. How Nautical Charts are Made.....	6
4. Accuracy of NOAA Nautical Charts	6
5. Types of Nautical Charts – Paper, RNC, ENC... ..	11
6. NOAA Custom Charts.....	15
7. NOAA ENC Viewer.....	15
8. Principal IHO Standards for ENC Charts.....	20
9. Chart Scales	20
10. NOAA ENC Design Scheme.....	21
11. National Charting Plan	29
12. Chart Updates.....	30
13. Chart Resolution.....	30
14. Chart Symbols	32
15. Key Features of Paper Charts.....	42
16. Chart No 1	45
17. Key References for ENC Charts	47
18. Annex A – Regional ENC Chart Codes from NOAA ENC Design Scheme....	47

U.S. COAST GUARD AUXILIARY – DISTRICT 7

GUIDE TO NOAA NAUTICAL CHARTS

1. FUNDAMENTALS OF CHART MAKING

Maps and charts are based on two concepts – the shape of the earth and the creation of a flat (two-dimensional) representation of that surface.

The Shape of the Earth

The Greeks are credited with creating the concepts of latitude and longitude. For chart making, they assumed the earth was a sphere. In the sixteenth century, advances in equipment, methods and understanding allowed precise astronomical observations and accurate measurements of angles and distance. Coastal surveying was done by establishing locations on shore using astronomical sightings and then measuring distances from those points. Offshore measurements were made by much less-accurate shipboard astronomical observations. That methodology, with improvements, remained the basis of surveying until the advent of satellite-based measurement systems.

As measurements become more precise and extensive, it was necessary to move from the spherical model to the ellipsoid or spheroid – in simple terms a flattened or oblate sphere. In the nineteenth century, accurate ellipsoid models were developed for local use in various countries. More recently, starting at a point in Kansas, what is now the National Geodetic Survey established the North American Datum of 1927 (NAD27). This is still the basis of most US cartographic maps.

The actual shape of the earth is neither a sphere nor an ellipsoid. It is a geoid. A geoid is the surface within or around the earth that is everywhere normal to the direction of gravity and coincides with mean sea level. The geoid may be higher or lower than any ellipsoid model at a given point. If the geoid undulates above the ellipsoid, then the surface distance between two points that have been located by astronomical measurements will be greater than the prediction of the ellipsoid model.

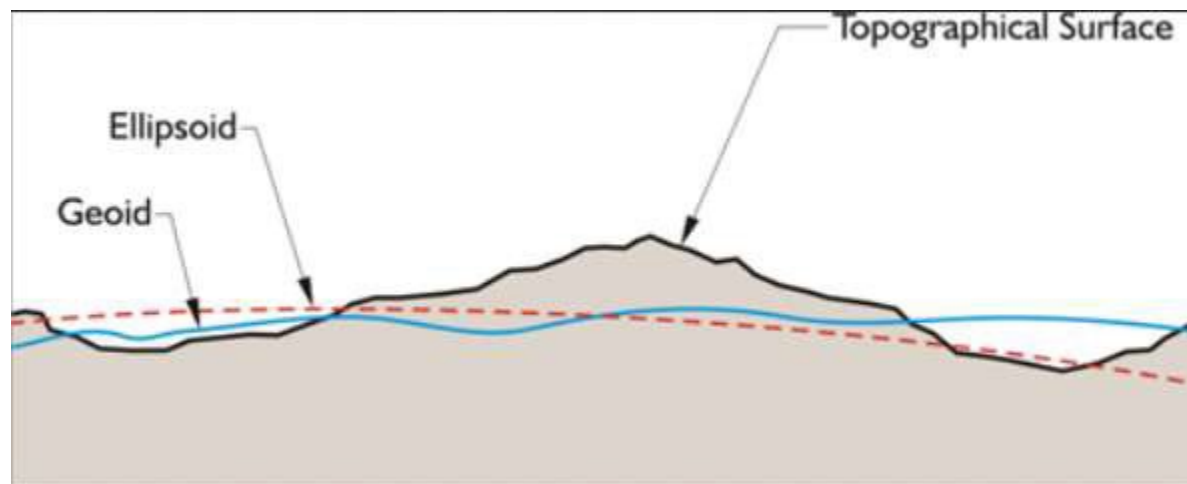

The real problem with local ellipsoid models is that while adequate in their region, they do not fit together to create a global model.

Now, using satellites and laser measurements, a global datum model (WGS84) has been established. All GPS data uses the WGS84 datum. In WGS84, the earth is an ellipsoid with a semi-major axis (at the equator) of 6,378,137.0 meters and a semi-minor axis of 6,356,752.3 meters (through the poles).

NOAA paper charts use the NAD83 model. For practical purposes in navigation, NAD83 is equivalent to WGS84 within 2 meters. However, some GPS users set their receivers to NAD83 in the belief that correlates to the chart values. A GPS receives native WGS84 data. To convert to NAD83, they use algorithms which can generate large errors in some locations. A marine GPS should always be operated in WGS84 mode when used with NOAA charts.

Using WGS84 GPS data with a US map or old coastal chart based on NAD27 can lead to errors over 300 feet. Large errors can occur when using GPS in conjunction with any chart not based on WGS84/NAD83.

Portions of some charts, even in US waters, are based on surveys from the eighteenth or nineteenth century with large inaccuracies. In these areas, the precision of the GPS creates a false sense of security.

Latitude and longitude values are not unique. They are relative to the datum used to specify them. A given point in the U.S. has one lat/long in WGS84 and a different value in NAD27.

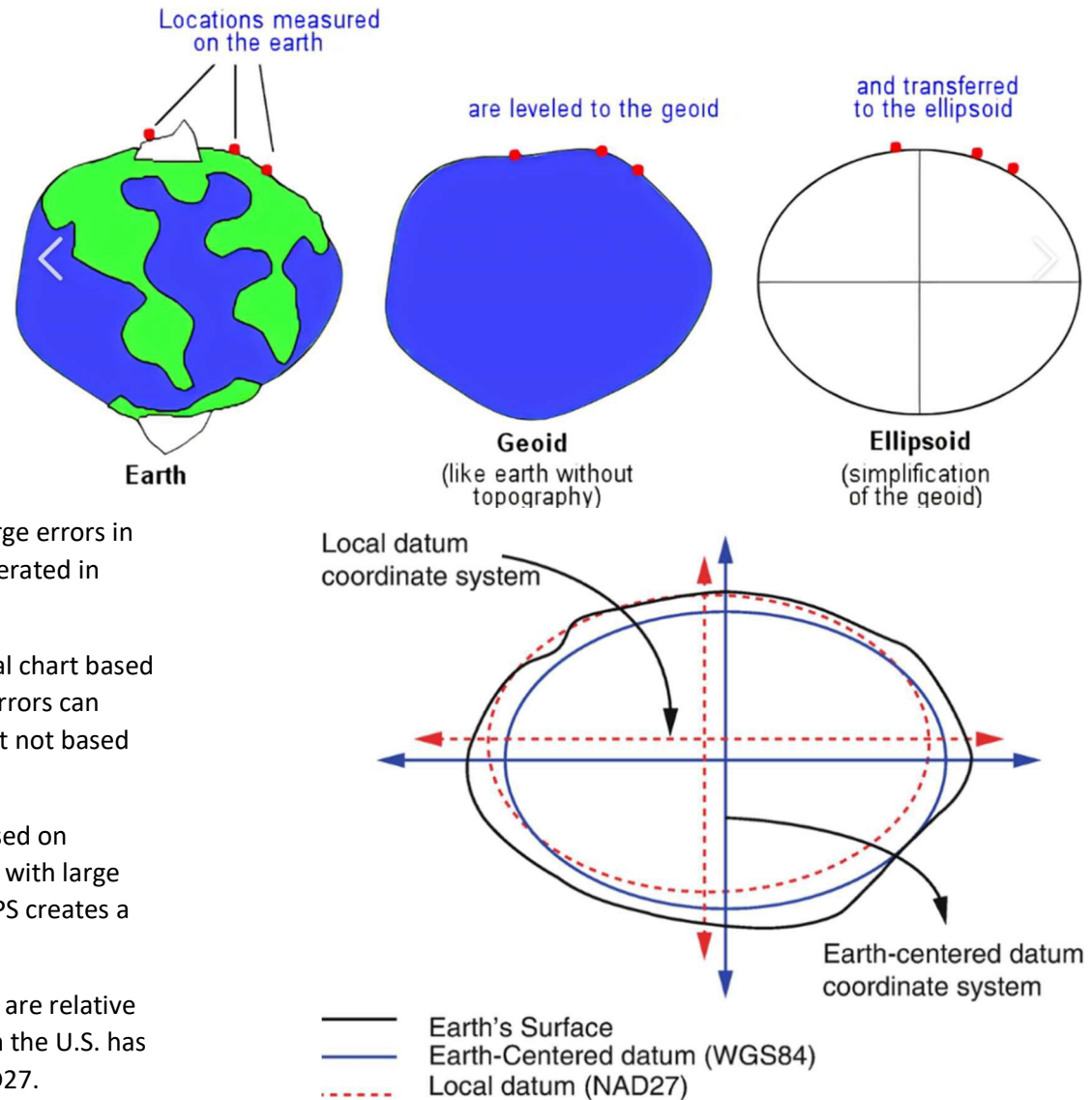

2. CHART PROJECTIONS

Mercator

The most common projection for nautical charts is the Mercator. It may be visualized as wrapping a cylinder around the earth and projecting every point on the planet onto the cylinder. When the cylinder is unwrapped and laid flat, it has a two-dimensional representation of the earth's surface. Horizontal distances at the equator are accurate, but moving north or south, distortion increases, and distances become progressively exaggerated.

Meridians of Longitude are great circles which pass through both north and south geographic poles. A great circle is one whose center is at the center of the earth. Longitude is a measure of distance east or west of a reference or prime meridian, which passes through Greenwich, England. The maximum values are ± 180 degrees.

Parallels of Latitude are circles parallel to the equator. The distance between the circles is constant, but their diameters decrease with distance from the equator. Latitude is a measure of distance north or south of the equator. The maximum values are ± 90 degrees.

On a Mercator chart, meridians of longitude and parallels of latitude are straight lines running vertically and horizontally. This makes it easy to use for plotting, especially over short distances, hence the popularity of this projection.

Standard
Mercator
Projection

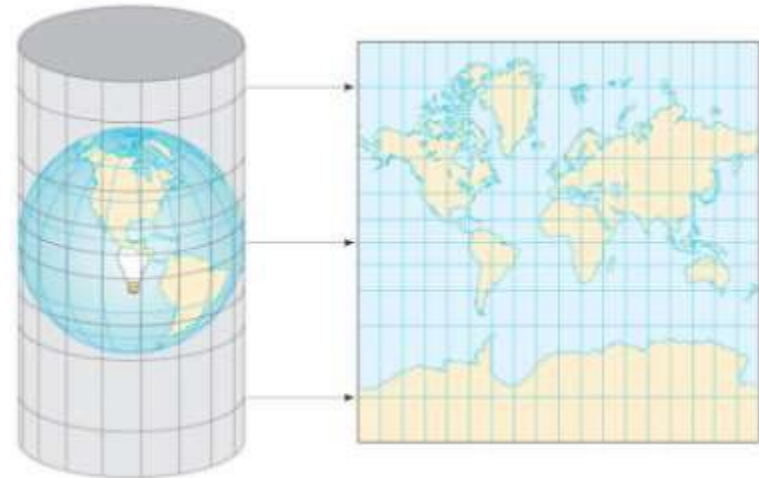

Transverse Mercator charts are made by wrapping the cylinder horizontally around the globe, so the axis of the cylinder is parallel to the equator. This projection is used to create highly accurate maps of small ranges of latitude anywhere on the earth by locating the axis of the cylinder at the desired latitude.

Polyconic

Polyconic projections are created by draping cones over the earth with the apex of the cones over one or both geographic poles. The resulting charts are butterfly-shaped, with outer edges that are curved lines of longitude. Distortion increases when moving either east or west of the chart's central meridian. The distortion is both of distance and shape.

Polyconic charts are generally used for small areas. Some NOAA charts of the Great Lakes are polyconic.

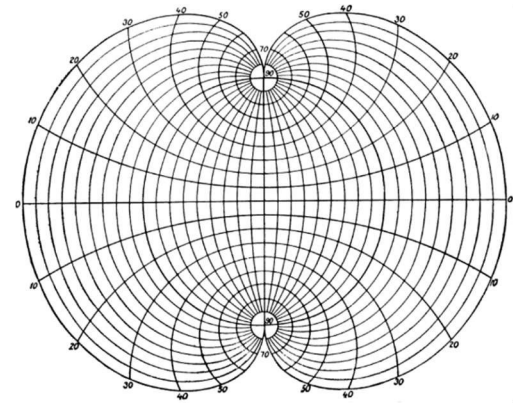

Lambert Conformal Conic

Lambert conformal conic projection is used for aeronautical charts, and the U.S. State Plane Coordinate System of 1983. This projection sets a cone over the surface of the earth and projects the surface conformally onto the cone. When the cone is unrolled, the parallel (of latitude) that was touching the spheroid has unit scale, meaning no distance distortion. Two parallels can be created with unit scale. The Lambert conformal projection is very accurate in the area that lies between the two parallels.

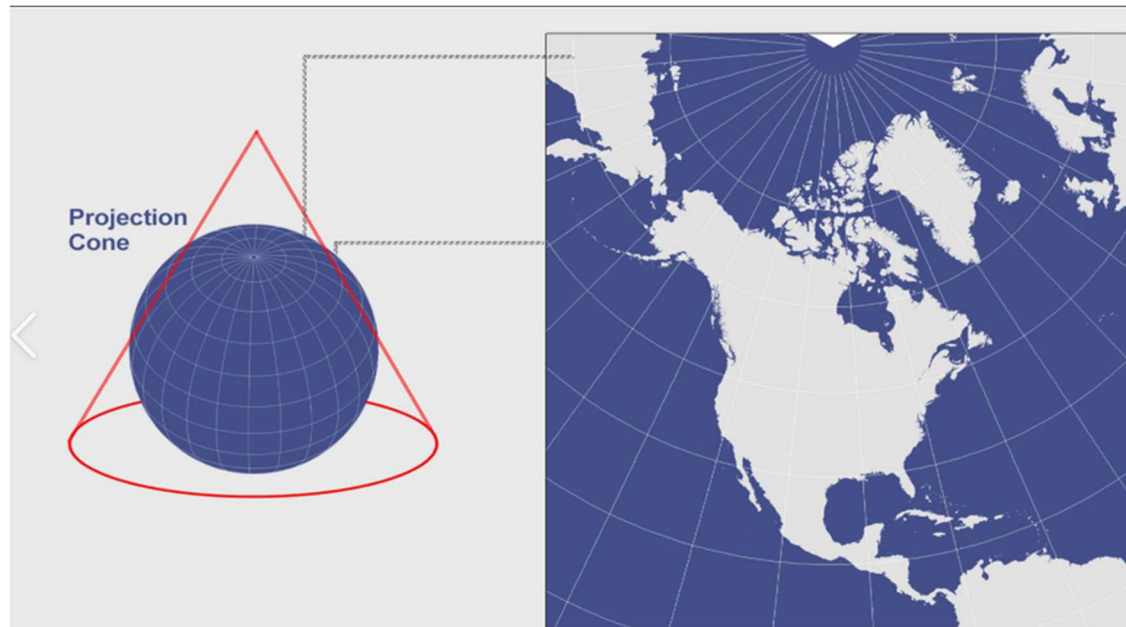

Gnomonic

A gnomonic chart displays all great circles as straight lines. The surface of the earth is cast onto a tangent plane. Distortion increases rapidly away from the tangent plane. No more than one-half the globe can be displayed on a single chart.

The benefit of a gnomonic chart is that it displays the shortest distance between two widely separated points as a straight line. This makes it suited to plotting great circle courses over long distances.

NOAA does not produce gnomonic charts. Most gnomonic charts are from the British Admiralty

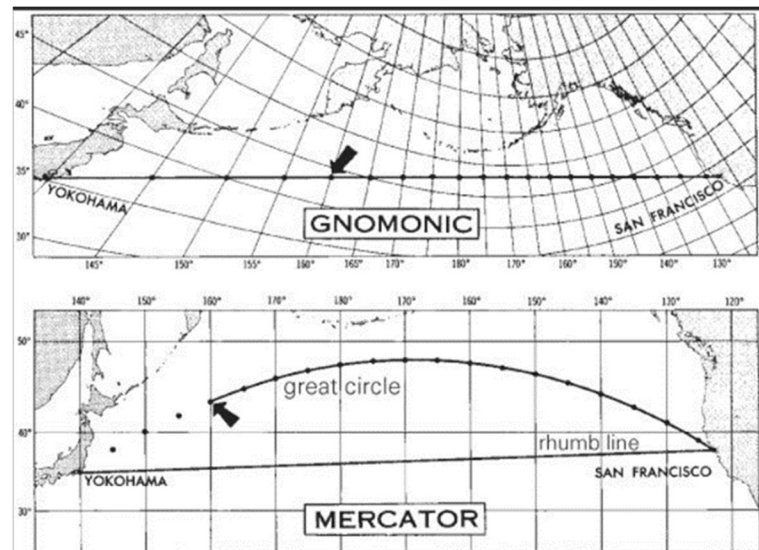
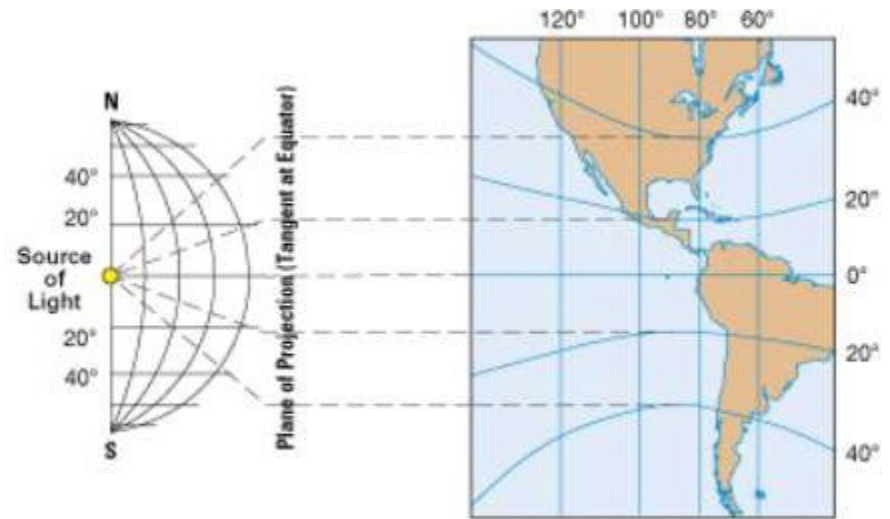

3. HOW NAUTICAL CHARTS ARE MADE

Nautical charts are based on hydrographic surveys. Surveys lay out the positions and features of coastlines and other surface objects. Historically, these were done by measurement from the land, whenever possible, or by astronomical observations made aboard ship, which are much less accurate than those taken on shore. Depth and bottom characteristics were determined by sounding with a line, and later with electronic fathometers.

These surveys were the basis for all paper charts and their derivatives. The latest electronic charts use surface features determined by accurate GPS measurements and detailed depth sounding.

4. ACCURACY OF NOAA NAUTICAL CHARTS

NOAA in 2016 began introducing zones of confidence for charts. This is a recognition of the limits of chart accuracy when based on old or incomplete survey data. This is based on IHO S-67 *Mariner’s Guide to the Accuracy of Electronic Navigation Charts*.

NOAA ZOC (ZONE OF CONFIDENCE) CATEGORIES				
ZOC	DATE	POSITION ACCURACY	DEPTH ACCURACY	SEAFLOOR COVERAGE
A1	2008 or later	± 16 ft	= 1.6 FT + 1% of depth	All significant seafloor features detected
B	1949	± 160 ft	= 3.2 ft + 2% of depth	Uncharted features hazardous to surface navigation are not expected by may exist
C	1949	± 1600 ft	= 6.5 ft + 2% of depth	Depth anomalies may be expected
D		Worse than ZOC C	Worse than ZOC C	Large depth anomalies are to be expected

According to NOAA’s Office of Coast Survey:

The age and accuracy of data on nautical charts can vary. Depth information on nautical charts, paper or digital, is based on data from the latest available hydrographic survey, which in many cases may be quite old. In too many cases, the data is more than 150 years old. Sometimes, particularly in Alaska, the depth measurements are so old that they may have originated from Captain Cook in 1778.

Mariners need to know if data is old. They need to understand the capabilities and the limitations of the chart. In particular, the mariner should understand that nautical chart data, especially when it is displayed on navigation systems and mobile apps, possess inherent accuracy limitations.

Before the advent of GPS, the position accuracy of features on a paper chart was more than adequate to serve the mariner's needs. Twenty years ago, mariners were typically obtaining position fixes using radar ranges, visual bearings, or Loran C. Generally, these positioning methods were an order of magnitude less accurate than the horizontal accuracy of the survey information portrayed on the chart. Back then, Coast Survey cartographers were satisfied when we plotted a fix with three lines of position that resulted in an equilateral triangle whose sides were two millimeters in length at a chart scale of 1:20,000. In real world coordinates, the triangle would have 40-meter sides. Close enough!

Now, with GPS, charted locations that are off by 10 or 15 meters are not nearly close enough. Mariners now expect, just as they did 30 years ago, that the horizontal accuracy of their charts will be at least as accurate as the positioning system available to them. Unfortunately, charts based on data acquired with old survey technologies will never meet that expectation.

Source data is deficient by today's standards:

The overall accuracy of data portrayed on paper charts is a combination of the accuracy of the underlying source data and the accuracy of the chart compilation process. Most nautical charts are made up of survey data collected by various sources over a long time. A given chart might encompass one area that is based on a lead line and sextant hydrographic survey conducted in 1890, while another area of the same chart might have been surveyed in the year 2000 with a full-coverage shallow-water multibeam echo sounder.

In general, federal hydrographic surveys have used the highest standards, with the most accurate hydrographic survey instrumentation available at the time. On a 1:20,000-scale chart, for example, the survey data was required to be accurate to 15 meters. Features whose positions originate in the local notice to mariners, reported by unknown source, are usually charted with qualifying notations like position approximate (PA) or position doubtful (PD). The charted positions of these features, if they do exist, may be in error by miles.

Similarly, the shoreline found on most NOAA charts is based on photogrammetric or plane table surveys that are more than 30 years old.

Another component of chart accuracy involves the chart compilation process. Before NOAA's suite of charts was scanned into raster format in 1994, all chart compilation was performed manually. Cartographers drew projection lines by hand and plotted features relative to these lines. They graphically reduced large-scale (high detail) surveys or engineering drawings to chart scale. Very often, they

referenced these drawings to state or local coordinate systems. The data would then be converted to the horizontal datum of the chart, e.g., the North American 1927 (NAD27) or the North American Datum 1983 (NAD83). In the late 1980s and early 1990s, NOAA converted all its charts to NAD83, using averaging techniques and re-drawing all the projection lines manually.

When NOAA scanned its charts and moved its cartographic production into a computer environment, cartographers noted variations between manually constructed projection lines and those that were computer-generated. They adjusted all the raster charts so that the manual projection lines conformed to the computer-generated projection.

Many electronic chart positional discrepancies that are observed today originate from the past graphical chart compilation techniques. The manual application of survey data of varying scales to the fixed chart scale was a source of error that often introduced biases. Unfortunately, on any given chart, the magnitude and the direction of these discrepancies will vary in different areas of the chart. Therefore, no systematic adjustment can automatically improve chart accuracy.

Coast Survey is addressing the accuracy problem:

NOAA's suite of over a thousand nautical charts covers 95,000 miles of U.S. coastline, and includes 3.4 million square nautical miles of U.S. jurisdiction within the Exclusive Economic Zone (which is an area that extends 200 nautical miles from shore.) About half of the depth information found on NOAA charts is based on hydrographic surveys conducted before 1940. Surveys conducted with lead lines or single-beam echo sounders sampled a small percentage of the ocean bottom. Due to technological constraints, hydrographers were unable to see between the sounding lines. Depending on the water depth, these lines may have been spaced at 50, 100, 200, or 400 meters. Today, as NOAA and its contractors re-survey areas and obtain full-bottom coverage, we routinely discover previously uncharted features (some that are dangers to navigation). These features were either: 1) not detected on prior surveys; 2) man-made objects, like wrecks and obstructions, that have appeared on the ocean bottom since the prior survey; or 3) the result of natural changes that have occurred since the prior survey.

Coast Survey is also improving our chart production system. As NOAA developed its charts over the centuries, cartographers relied on separate sets of data: one set for traditional paper charts, and another for the modern electronic navigational charts. We are currently integrating a new charting system that will use one central database to produce all NOAA chart products. The new chart system slims down the system while it beefs up performance, speeding new data and updates to all chart versions of the same charted areas and removing inconsistencies.





The IHO (International Hydrographic Organization) Standard S-44 establishes minimum accuracy standards for hydrographic surveys.

IHO S-44 MINIMUM BATHYMETRY STANDARDS					
Criteria	Order 2	Order 1b	Order 1a	Special Order	Exclusive Order
Area Description	Areas where a general description of the sea floor is considered adequate	Areas where under keel clearance is not considered to be an issue for the type of surface shipping expected to transit the	Areas where under keel clearance is considered not to be critical but features of concern to surface shipping may exist	Areas where under keel clearance is critical	Areas where there is strict minimum under keel clearance and maneuverability criteria
Depth – Total Horizontal Uncertainty	20 m + 10% of depth	5 m + 5% of depth	5 m + 5% of depth	2 m	1 m
Depth – Total Vertical Uncertainty a varies with depth b does not vary	a = 1.0 m b = 0.023 m	a = 0.5 m b = 0.013 m	a = 0.5 m b = 0.013 m	a = 0.25 m b = 0.0075 m	a = 0.15 m b = 0.0075 m
Feature Detection	Not specified	Not specified	<i>Cubic features > 2 m in depths to 40 m; 10% of depth beyond</i>	Cubic features > 1 m	Cubic features > 0.5 m
Bathymetric Coverage	5%	5%	≤ 100%	100%	200%
Coastline	10 m	10 m	10 m	10 M	5 M

Most charts do not currently meet NOAA or IHC standards. The NOAA website provides a graphical presentation of the status of ENC charts for the United States (see NOAA ENC Chart Grids below). IHO C-55 *Status of Hydrographic Surveying and Charting Worldwide* provides data on the state of chart accuracy by country. The report on the United States dated 26 June 2021 is shown below. Only 11% of depths below 200 meters (656 ft.) are current. More detail on particular regions of the U.S. can be found in the IHO document.

United States of America (A)

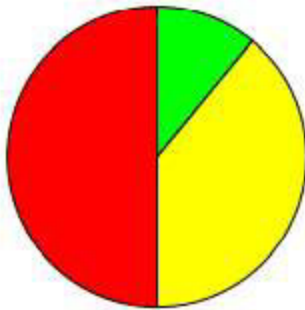
Hydrographic surveying / Levés hydrographiques / Levantamientos hidrográficos

Survey coverage Couverture hydrographique Cobertura hidrográfica		Depth < 200m Profondeur < 200m Profundidad < 200m			Depth > 200m Profondeur > 200m Profundidad > 200m		
 %	Adequately surveyed Correctement hydrographié Adecuadamente levantado	11	39	50	16	4	80
 %	Re-survey required Nécessitant de nouveaux levés Requiere nuevo levantamiento						
 %	Never systematically surveyed Jamais hydrographié systématiquement Nunca levantado sistemáticamente						
Notes Notes Notas	<p>Amplifying information:</p> <p>1. Special national circumstances which influence the statistical break-down above (e.g. geographical factors such as narrow continental shelf or fringing reefs, or constraints such as areas of unstable seabed which require a routine re-survey programme.</p> <p>The definitions provided regarding C-55 are very broad and general as to how the Hydrographic Office defines survey coverage. For this analysis Coast Survey used the following survey date ranges to determine the C-55 category.</p> <p>Depths less than or equal to 200 meters:</p> <ul style="list-style-type: none"> • 1994 - Present = A • 1940 - 1993 = B • Pre 1940 or un-surveyed = C <p>Depths greater than 200 meters to the extent of the EEZ:</p> <ul style="list-style-type: none"> • 1940 - Present = A • Pre 1940 (1851-1939) = B 						

Vector (ENC)

An ENC chart is a vector plot in using IHO standard format and symbols, displayed on a screen using appropriate software.

Each point on a vector chart contains the location and data for that point. Whereas the only information available on a raster chart is position and the printed symbols and text, each point on an ENC chart can display full information for that object or location (see Object Query).

During the initial transition to ENC, the charts were principally derived from raster charts. Vector charts derived from raster tended to be less accurate than the raster original. Because the vector chart places an object which may have occupied a matrix of pixels on the raster into a single vector, it can be 10 or more meters off its true position while offering a false sense of accuracy.

New ENC charts are generated directly from GNSS surveys and more complete bathymetric data (depths and sea floor surveys). See the Office of Coast Survey "Hydrographic Survey Specifications and Deliverables."

Vector charts are displayed using proprietary software on a chart plotter, computer, or mobile device. The result is that there are many variations in operability and more than one set of symbols.

NOAA/IHO has two basic symbol sets, (see Chart Symbols). There are also proprietary symbols used by various manufacturers. The display of symbols and text varies with the level of zoom. The user can also select what to display.

While RNC charts are always North Up, an ENC chart can be displayed with a variety of headings and will orient correctly.

ENC charts used with ECDIS systems can be set up to notify of dangerous conditions, such as shallow water, based on the characteristics of the vessel.

NOAA ENC charts use metric depth units, but users can often select the units.

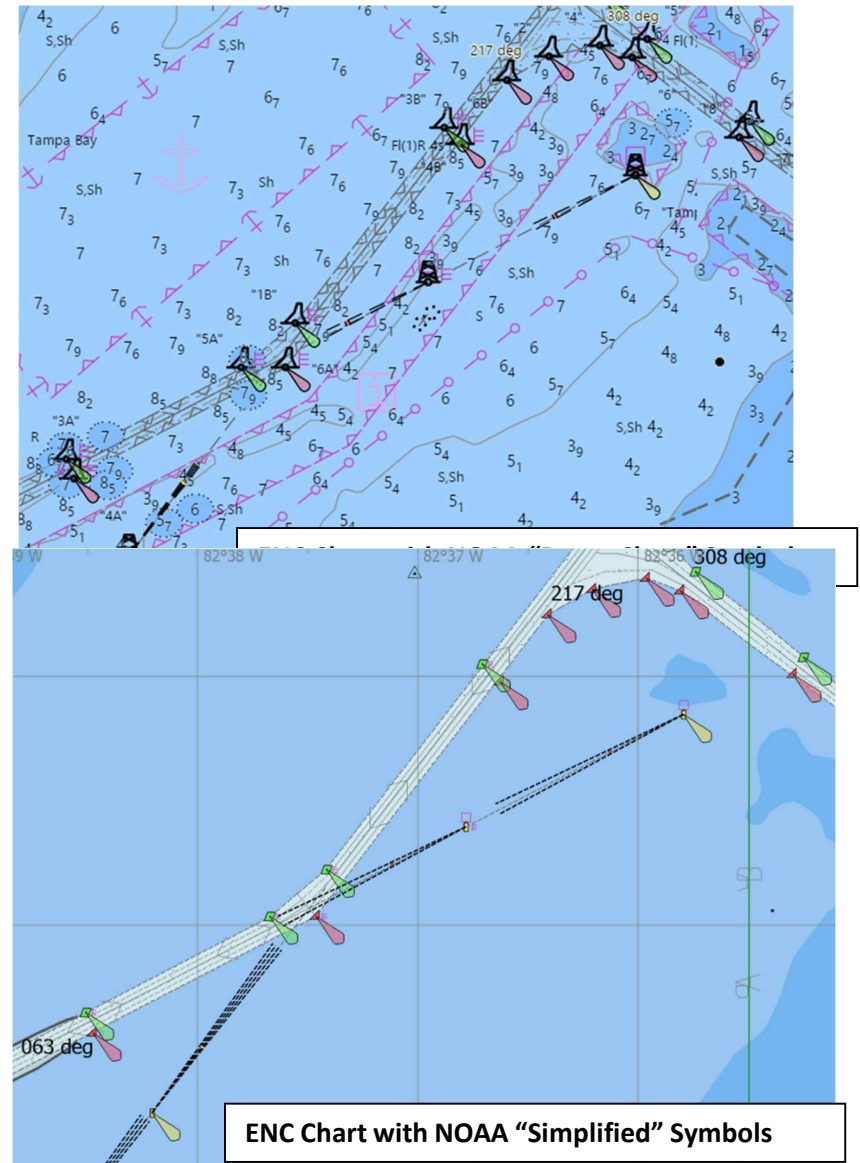

Object Query

U.S. COAST GUARD AUXILIARY D7 GUIDE TO NOAA NAUTICAL CHARTS
Example of an Object Query on an ENC chart

Light (LIGHTS)

27° 18' 55.113" N 082° 35' 53.167" W

Q (1) 1s 15.7 ft 4 Nm Night light.

Beacon, special purpose/general (BCNSPP)

27° 18' 55.113" N 082° 35' 53.167" W

CATGEO Point

BCNSHP lattice beacon(4)

COLOUR white (1), white (1), red (3)

COLPAT border stripes (6), vertical stripes (2)

OBJNAM New Pass Shoal Light

STATUS permanent (1)

SCAMIN (89999)

SORDAT 20170627

SORIND US,US,reprt,7thCGD,LNM 26/17

Daymark (DAYMAR)

27° 18' 55.113" N 082° 35' 53.167" W

CATGEO Point

COLOUR white (1), white (1), red (3)

COLPAT border stripes (6), vertical stripes (2)

TOPSHP other shape (see INFORM)(33)

INFORM Octagonal

SCAMIN (89999)

SORDAT 20170627

SORIND US,US,reprt,7thCGD,LNM 26/17

Sea area / named water area (SEAARE)

CATGEO Area

OBJNAM Gulf of Mexico

SCAMIN (44999)

SORDAT 201305

SORIND US,US,graph,Chart 11425

Depth area (DEPARE)

CATGEO Area

17.7 ft - 29.9 ft

Navigational system of marks (M_NSY)

CATGEO Area

MARSYS IALA B(2)

SORDAT 201305

SORIND US,US,graph,Chart 11425

Additional info files attached to: US5FL19M.000

[US5FL19A.TXT](#)

[US5FL19B.TXT](#)



The abbreviations in the Query are explained in IHO S-57.

Vector charts can be zoomed without changing the size of objects and text, but there is the potential to over zoom and create a false sense of accuracy.

At left, RNC and ENC charts zoomed to show the same pair of buoys.

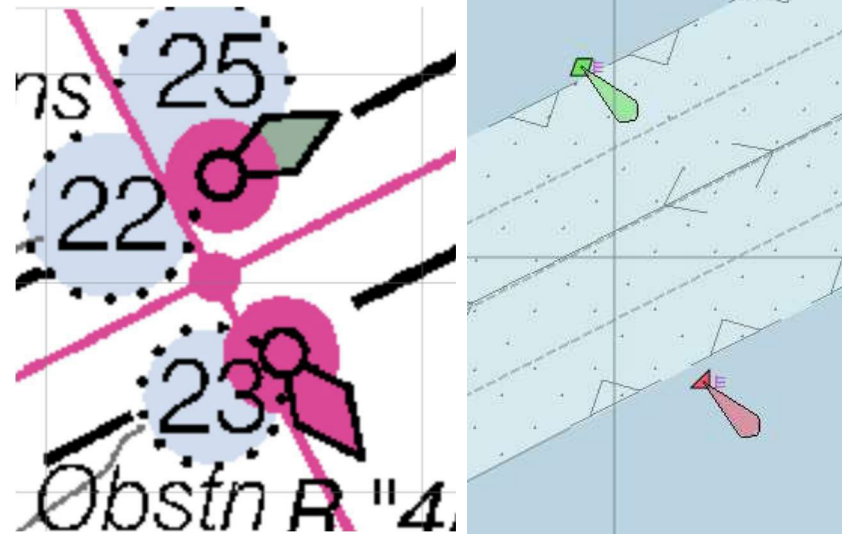
The comparison of RNC and ENC charts on the next page is from NOAA



<h2 style="text-align: center;">Raster Navigational Chart (RNC)</h2>	<h2 style="text-align: center;">Electronic Navigational Chart (ENC)</h2>
<div style="display: flex; align-items: center;"> <div style="border: 1px solid gray; padding: 2px; margin-right: 5px; font-size: 8px;">RASTER</div>  <p style="margin: 0;">Information is stored as raster data — rows and columns of color pixels.</p> </div>	<div style="display: flex; align-items: center;"> <div style="border: 1px solid gray; padding: 2px; margin-right: 5px; font-size: 8px;">VECTOR</div>  <p style="margin: 0;">Information is stored as vector data — pairs of coordinates that define the position and shape of points, lines, and area features.</p> </div>
<p>Each RNC pixel is assigned one color to display and is georeferenced to a particular latitude and longitude.</p>	<p>Pairs of latitude and longitude coordinates define nodes that form points, lines, and areas within a database. Each of these is encoded to represent one or more features. Each feature is further encoded with attributes that describe the characteristics of a specific instance of a real world feature.</p>
<p>Each RNC pixels “knows” what color it is and its location on the Earth, but nothing else about what it represents or its position relative to other features.</p>	<p>Each ENC feature “knows” what it is and other information about itself, such as buoy shape or clearance height. It also knows its location on the Earth, as well as its topological relation to other features. For example, an international boundary feature will know which country is on each of its sides.</p>
<p>All the information available in an RNC is presented in its symbolization. Thus, some portions of raster charts are cluttered with symbols and text to present all the needed information.</p>	<p>Users may “query” the ENC data by clicking the cursor on a feature to obtain more information about it. Information, such as light characteristics need not always be displayed in ECDIS, because it can be retrieved by a cursor query.</p>
<p>RNC systems do not provide automated alarms or other indications.</p>	<p>ECDIS systems use the information in ENCs and ship information provided by the mariner, such as the ship’s draft, speed, and direction to alert mariners with visual and auditory alarms when dangerous conditions may exist.</p>
<p>The depiction of features in raster charts is through the arrangement of pixels to form symbols when the data is compiled. The symbology cannot be changed. NOAA paper nautical charts and RNCs are created from the same digital chart images so RNCs are also displayed using “paper chart” symbology.</p>	<p>ENC data is rendered in real-time by ECDIS navigational systems in which standardized IHO ENC symbology is stored. Mariners may choose between two ENC symbology sets to display ENCs, “simplified” and “paper chart.” Non-ECDIS systems that can display ENC data may use other symbology developed by the manufacturer.</p>
<p>Although similar, RNCs and paper nautical charts produced by different countries will have variations in colors and some of the symbols.</p>	<p>Any ECDIS will portray all ENC data with the same colors and symbols, regardless of which country produced the ENC.</p>
<p>The symbols on an RNC enlarge and become “pixelated” as one zooms into the chart.</p>	<p>The symbols on an ENC remain the same size as one zooms into the chart.</p>
<p>The selection of the features to display on RNCs is set when it is compiled and cannot change.</p>	<p>The display of certain features in ENCs may be turned on or off, based on the scale of the chart display or by settings selected by the mariner.</p>
<p>Most RNCs are compiled in a “North-up” orientation. RNCs can be rotated to a “course-up” orientation in a chart display system, but the symbols and text will become tilted as the chart is rotated.</p>	<p>ENCs have no inherent orientation. The symbols and text displayed in an ECDIS will always be displayed facing up correctly.</p>
<p>NOAA RNCs conform to the International Hydrographic Organization S-61 Product Specification for Raster Navigational Charts.</p>	<p>NOAA ENCs conform to the International Hydrographic Organization S-57 Transfer Standard for Digital Hydrographic Data.</p>

6. NOAA Custom Charts

There is another option to create paper or pdf charts, although they do not meet the requirements for commercial use. NOAA has a free application that allows users to create their own paper or pdf charts derived from the official NOAA ENC charts. The information is current when it is downloaded and matches the most recent ENC chart. The data on the chart is presented in a manner similar to traditional paper nautical charts, including the depiction of soundings, aids to navigation, and compass roses.

7. NOAA ENC Viewer

NOAA's Office of Coast Survey offers an ENC viewer. This allows selection and display of any current ENC chart of the United States.

Once the chart is selected, the viewer offers numerous options to customize the display, as shown below.

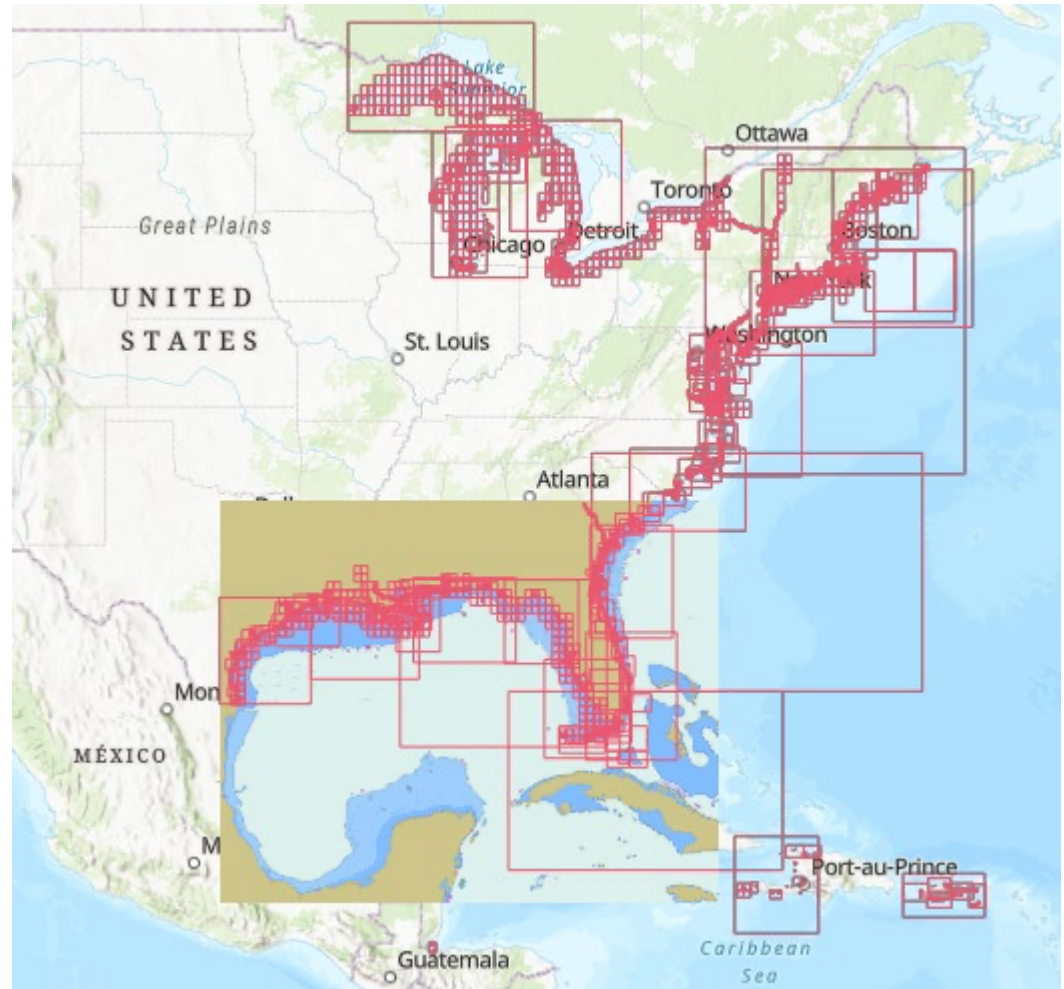

About

The NOAA ENC Viewer provides a continuous depiction of all NOAA ENC © coverage over U.S. coastal waters and the Great Lakes as would be shown on Electronic Chart Display and Information Systems (ECDIS). U.S. Chart No. 1 provides information about the symbology used in ECDIS.

The NOAA ENC Viewer provides features that can be leveraged in various GIS and OGC WMS compliant applications. ENC Viewer highlights many of the following features.

Generic features

- Displays the S-57 datasets using S-52 presentation library specification edition 3.4.
- Provides indexing for the S-57 attribute Object Name (OBJNAM)
- Provides access to S-57 attribute information
- Links external files to S-57 attributes
- Allows for the best scale data to be displayed similar to how an ECDIS displays best scale data based on the map scale as a user zooms in and out of the display.

Web application features

- Search entire service by object name (OBJNAM)
- Identify features and display their attributes in a pick list
- Zoom to selected features
- Change basemaps
- Measure area and distance, get coordinates
- Set safety, shallow and deep depth contours
- Switch between simplified and traditional symbols
- Change the background colors of the display
- Turn off certain features or adjust transparency

Users who want to display NOAA ENC Viewer as a backdrop for GIS applications should use:

Esri REST Service
OGC WMS 1.3 Compatible

Please note that certain functionality, such as identify and search, may not be supported by other GIS applications.
For more information about Esri technology, email maritime@esri.com.

NOTE: NOAA ENC Viewer is not certified for navigation. It does NOT fulfill chart carriage requirements for regulated commercial vessels under Titles 33 and 48 of the Code of Federal Regulations.

Find address or place

27°43'27.19" N 82°39'56.49" W

0.6mi

The image shows a digital nautical chart viewer interface. At the top, there is a search bar with the text "Find address or place" and a magnifying glass icon. Below the search bar is a toolbar with icons for home, layers, settings, information, and search. The main map area displays a nautical chart of the Pinellas Bayway region, including features like Isla del Sol, Pinellas Bayway, Bird Key Middle Ground, Cow Key, Boca Ciega Bay, and Cabbage Key. The chart shows depth contours, navigational aids (beacon "13", "12", "26A", "25", "8", "23", "22", "20", "19", "21"), and various symbols for hazards and structures. Labels for "Isla del Sol", "Pinellas Bayway", "Bird Key Middle Ground", "Cow Key", "Boca Ciega Bay", "Cabbage Key", "Tierra Verde", "Frenchman Creek", "Maximo Point", and "Cats Point" are visible. The interface includes a sidebar on the left titled "Maritime Display Properties" with the following settings:

- Depth Contour (Meters): Miscellaneous
- Area symbolization: Symbolized boundari
- Attribute Description: Acronym
- Color scheme: DAY
- Compass rose: On (toggle)
- Data extents: Automatic
- Data quality: On (toggle)
- Depth units: Meters
- Display categories: DISPLAYBASE, STANDARD, OTHER
- Display frame text: Off
- Display frame text placement: Upper left
- Honor SCAMIN: On (toggle)

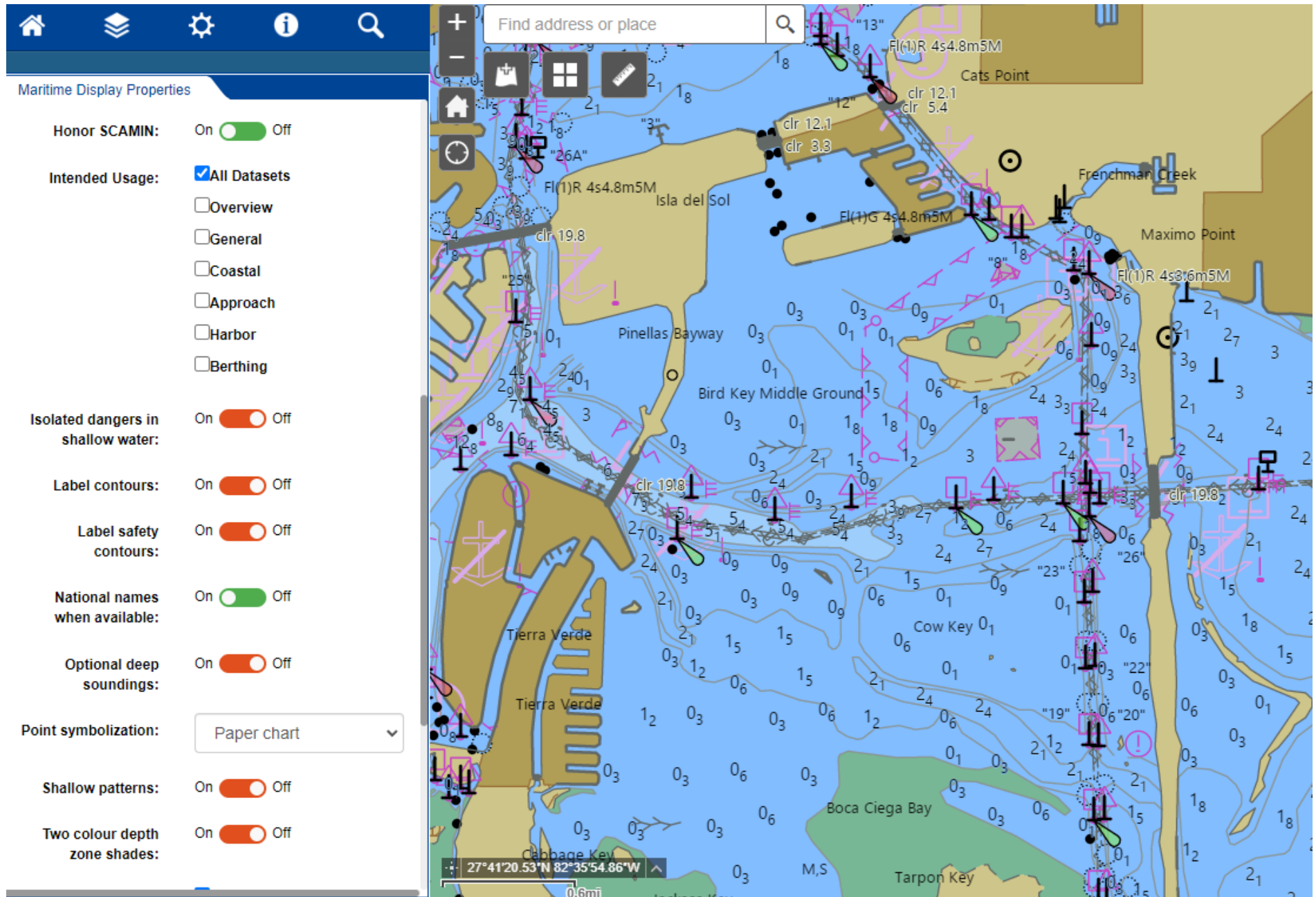

Label safety contours: On Off
 National names when available: On Off
 Optional deep soundings: On Off
 Point symbolization: Paper chart
 Shallow patterns: On Off
 Two colour depth zone shades: On Off
 Text groups:

- Important text
- Names for position reporting
- Light description string
- Note on chart data
- Nature of seabed
- Geographic names
- Magnetic variation and swept depth
- Height of islet or land feature
- Berth number
- Current Velocity

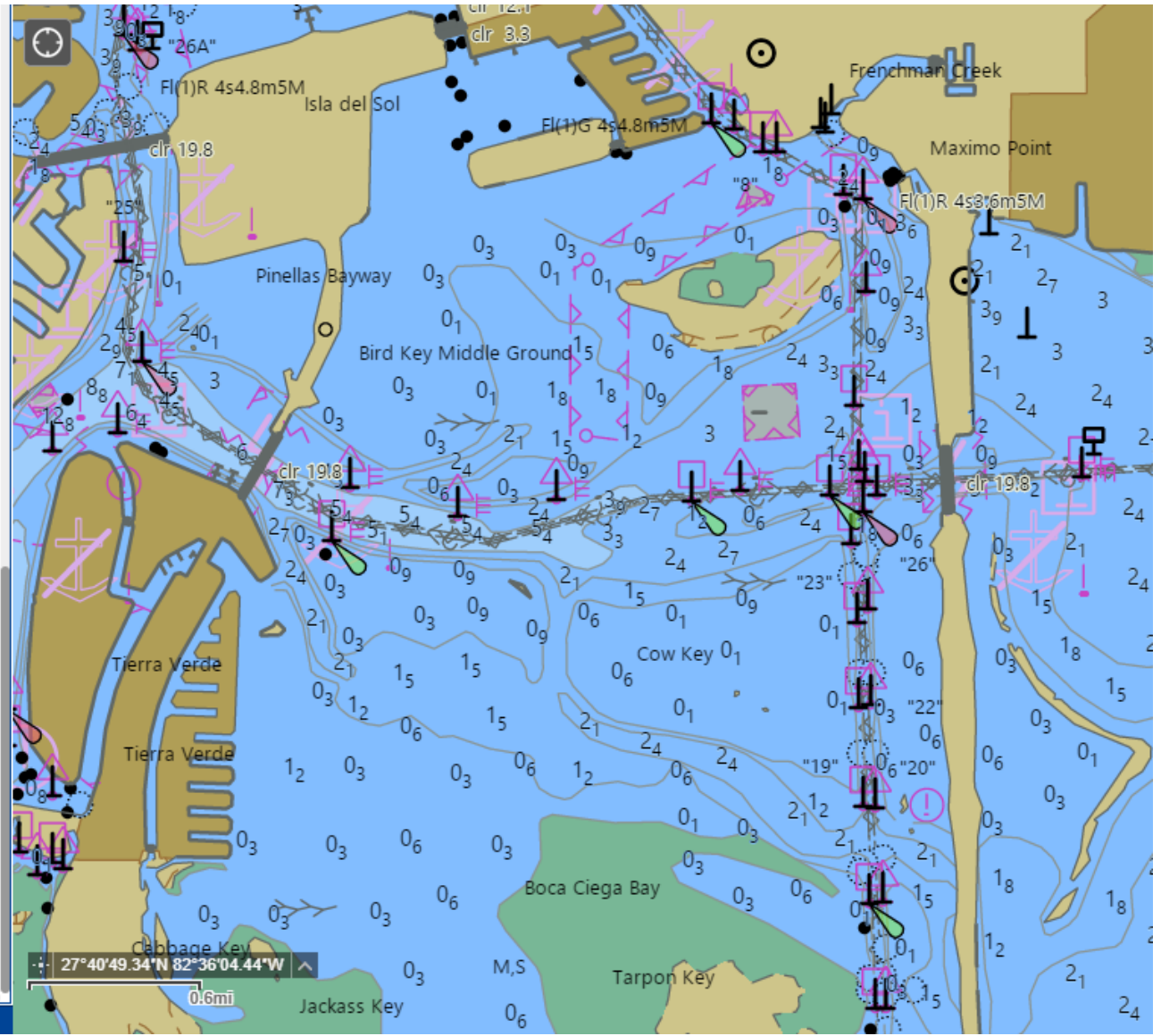

8. Principal IHO Standards for ENC Charts

- S-52 IHO Specifications for Chart Content and Display Aspects of ECDIS
- S-57 IHO Transfer Standard for Digital Hydrographic Data
- S-63 IHO Data Protection Scheme
- S-64 IHO Test Data Sets for ECDIS (Electronic Chart Display and Information System)
- S-65 ENCs: Production, Maintenance and Distribution Guidance
- S-66 Facts about Electronic Charts and Carriage Requirements
- S-67 Mariner’s Guide to the Accuracy of Electronic Navigation Charts
- S-101 The Next Generation ENC Product Specification

S-61 is the standard for RNC charts. All these standards are available for download at no charge from the IHO website.

9. CHART SCALES

Chart scales are the ratio of the distance on the chart to the distance on the earth. If 1 unit of distance on the chart equals 40,000 units of distance on the earth, the chart scale is 1:40,000. The meaning of large and small scale is confusing and seems counter-intuitive. A 1:40,000 chart is considered a larger scale than a 1:400,000 because 1/40,000 is a larger number than 1/400,000. It helps some people to think of large meaning a large amount of detail. The lower the second number in the scale, the more detail a chart shows. The chart opposite shows the historical scales of NOAA paper/RNC charts.

NOAA RNC CHART SCALES	
SAILING	≤ 1:600,000
GENERAL	1:150,000 – 1:599,999
COASTAL	1:50,000 – 1:149,999
HARBOR	< 1:50,000

10. NOAA ENC DESIGN SCHEME

NOAA published a reference document entitled “NOAA ENC Design Handbook,” dated June 1, 2024. This section is a reproduction of that document.

Purpose and Scope

The arrangement or layout of a set of charts is called a scheme. It is the systematic configuration of chart "footprints." NOAA is creating a new gridded layout of rectangularly shaped cells for its electronic navigational chart (NOAA ENC®) product suite. This handbook collects the relevant design characteristics for the size, shape, and arrangement of reschemed NOAA cells – and a few other key characteristics – that are specified in the Marine Chart Division (MCD) Nautical Chart Manual (NCM). It can serve as a handy reference for information that is spread throughout the NCM. The handbook is intended to be informative, not authoritative. For any conflict between the information in this handbook and the descriptions and specifications of the new ENC scheme in the NCM, the guidance and specifications found in the NCM shall prevail.

The rescheming of each legacy ENC cell is accomplished in several phases, shown in Figure 7.1. When a reschemed ENC cell is released to the public, it reflects changes and improvements made during one or more of these phases, which may be applied in various orders and combinations. This document only discusses the gridding and metrification portions of the overall ENC rescheming process.

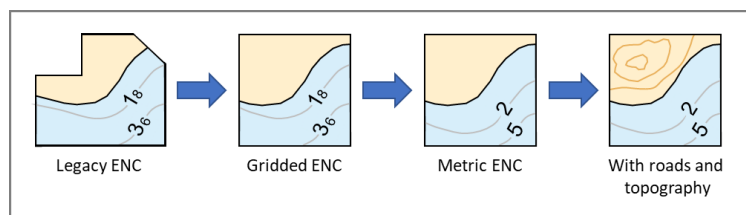

Figure 7.1. Basic steps of the NOAA ENC rescheming process.

The new scheme for all NOAA ENCs may be seen on the [Status of New NOAA ENCs](#) web map, which also shows the ongoing progress of gridding the NOAA ENC product suite. Blue rectangles show planned ENC footprints, red cells are in work, yellow cells in review, and green cells have completed the gridding phase and are available to the public.

ENC usage bands and standard scales

ENCs are categorized into six usage bands, sometimes called scale bands. The original ENC scheme used over 100 compilation scales ranging from 1:2,500 to 1:10,000,000. The new ENC scheme uses only 12 scales, two for each of the six ENC usage bands, as shown in Table 7.1.

Table 7.1. New Standard ENC Compilation Scales.

ENC Usage Band	Navigational Purpose	Standard ENC Scales
1	Overview	1:10,000,000 1:3,500,000
2	General	1:1,500,000 1:700,000
3	Coastal	1:350,000 1:180,000
4	Approach	1:90,000 1:45,000
5	Harbor	1:22,000 1:12,000
6	Berthing	1:4,000 1:2,000

After NOAA established one set of 12 standard compilation scales for the reschemed ENC design, the International Hydrographic Organization finalized the standard minimum and maximum display scales defined in the new S-101 ENC Product Specification, which are shown in Table 1. NOAA ENCs (all of which are currently in the old IHO S-57 ENC format) will now transition to the new S-101 scales in preparation for production of both ENC formats starting in 2026.

Standard ENC cell shape and size

The new ENC layout consists of nested rectangular cells, with boundaries following lines of longitude and latitude. Sixteen larger scale ENC cells fit inside one cell of the next smaller scale band. Figure 7.2 shows how 16 band 3 cells (green squares) fit inside one band 2 cell (brown square) and the relative sizes of cells in other bands. Figure 7.3 shows an example of nested, reschemed cells in bands 2 through 5 covering the California Coast from San Francisco to the Channel Islands.

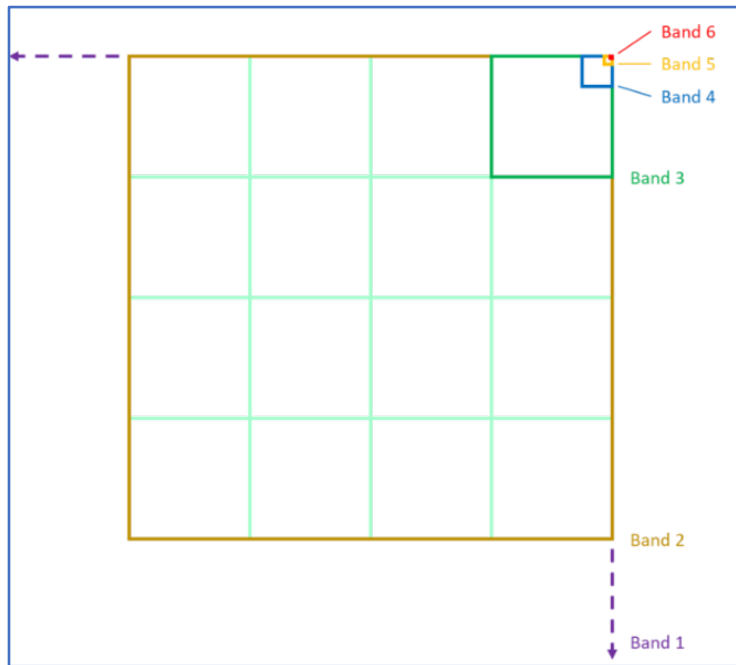

Figure 7.2. Nesting of reschemed ENC cells.

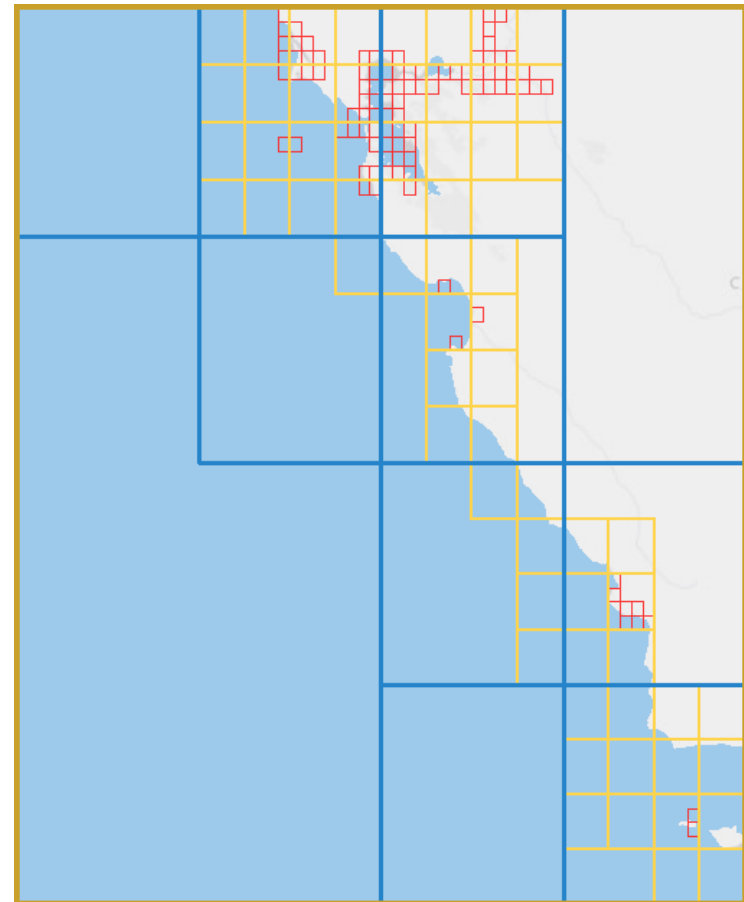
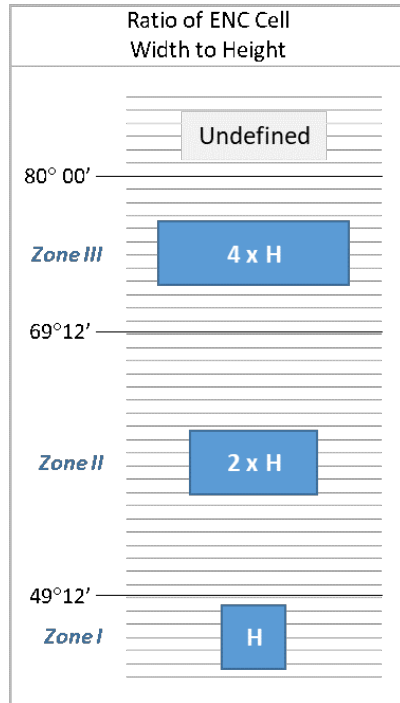
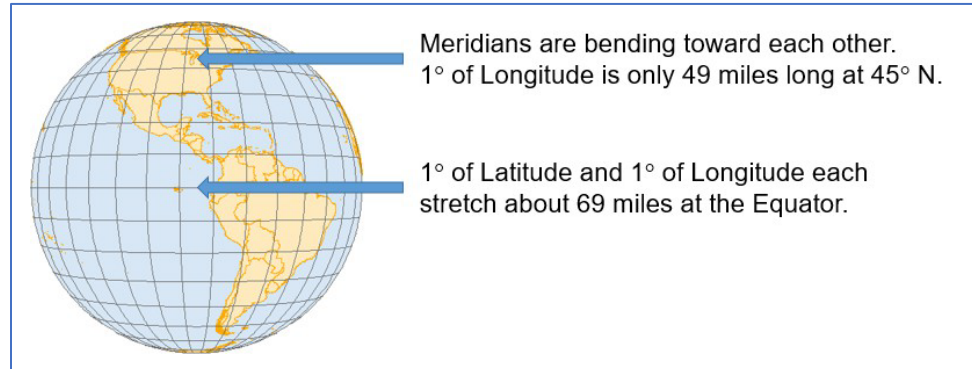

Figure 7.3. Reschemed ENC cells along the California coast, band 2 (brown), band 3 (blue), band 4 (yellow), and band 5 (red).

Latitude-based ENC cell width

On the globe, lines of longitude – also called meridians – converge at the Poles. Thus, the area of the Earth covered by ENC cells defined by equal extents of latitude and longitude will be narrower for ENC cells further away from the Equator. Reschemed ENC cells take this narrowing into account. Cells closer to the poles are widened by increasing their longitudinal extent as a multiple of their height.

Figure 7.4. Distance between meridians decreases as they converge at the poles.



The reschemed ENC design calls for cells to be wider longitudinally as they get closer to the poles, so the extent of the coverage "on the ground" does not become too narrow. For bands 3-5, the width of reschemed ENCs is specified by their location within three zones of latitude, as shown in Figure 5. The assignment of zones for bands 1 and 2 are determined by a different method, but they use the same multiples of height. The extents of band 6 cells are established on a case-by-case basis and may not follow the widths specified in Table 7.2.

Figure 7.5. Latitudinal zones used to specify the widths of band 3-5 ENC cells, as a multiple of height (H).

Table 7.2 shows cell widths in decimal degrees of longitude, for each zone, for each usage band. Cell dimensions are the same for both of the two standard scales in each usage band. For example, the height of all band 3 ENC cells is 1.2° in latitude. Band 3 cells below 49° 12' N fall into Zone I and have a cell width equal to their height, or 1.2° in longitude. Band 3 cells falling between 49° 12' N and 69° 12' N are in Zone II and have a width of twice their height, or 2.4° in longitude. The width of cells falling in Zone III is four times their height, or 4.8° in longitude.

Table 7.2. New Standard ENC Cell Dimensions.

Usage Band	Navigational Purpose	Standard Scales	Height	Zone I Width = H	Zone II Width = 2xH	Zone III Width = 4xH
1 [1]	Overview	1:10,000,000 1:3,500,000	19.2°	19.2°	38.4°	76.8°
2 [2]	General	1:1,500,000 1:700,000	4.8°	4.8°	9.6°	19.2°
3	Coastal	1:350,000 1:180,000	1.2°	1.2°	2.4°	4.8°
4	Approach	1:90,000 1:45,000	0.3°	0.3°	0.6°	1.2°
5	Harbor	1:22,000 1:12,000	0.075°	0.075°	0.15°	0.3°
6 [3]	Berthing	1:4,000 1:2,000	0.0375°	0.0375°	0.075°	0.15°

Table notes:

- [1] Band 1 ENCs will be some of the last cells created as part of the rescheming effort and their final configuration has not yet been established.
- [2] All band 2 ENCs within the contiguous 48 states are considered to be in Zone I. Band 2 ENCs west of Washington State in the North Pacific are considered to be in Zone II, except for ENCs in Alaska covering Point Hope, the North Slope, and the Arctic Sea, which are considered Zone III.
- [3] The extents of band 6 ENCs are established on a case-by-case basis and are generally smaller than the standard sizes shown in Table 2. Most band 6 cells retain the size and shape of the legacy paper charts from which they were originally digitized but are nevertheless considered to be part of the "reschemed" ENC product suite.

Naming Convention for NOAA Reschemed ENC Cells

All ENC file names throughout the world consist of eight characters; the first two characters hold the producer code, as listed in the International Hydrographic Organization (IHO) [S-62, List of IHO Data Producer Codes](#) – "US" is the NOAA producer code. The third character is the ENC usage band number (1 - 6). The remaining five characters of the file name are defined differently by various ENC producers. For NOAA ENCs, characters 4 through 6 hold a regional reference code and characters 7 and 8 hold the cell's matrix position within its region.

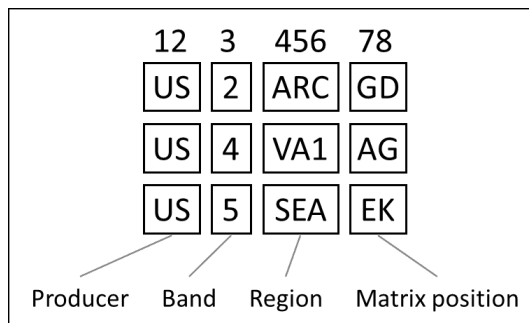

Figure 7.6. Three examples of the components of an 8-character reschemed ENC cell name: a band 2 cell in the Arctic, a band 4 cell in Virginia, and a band 5 cell covering the Port of Seattle.

There are several types of regional codes (see Annex A for a complete list). All NOAA band 1 cells are in the Global region and use the code "GLB." Regions for band 2 cells are based on oceans, other large water bodies, and the two polar regions, such as Pacific (PAC), Great Lakes (GRL), and Arctic (ARC). Regions in bands 3 and 4

are based primarily on US Postal Service two-letter abbreviations for US states and territories and a few other designations, such as Cuba (CU), Antarctic Treaty (AQ), and US Minor Outlying Islands (UM), which includes Howland Island and Johnston Atoll. After the two-letter abbreviations, the number 1 usually makes up the final part of the three-character regional code. If a region is large, it will be broken into smaller parts – especially in band 4, such as California, which has CA1 and CA2. The final type of regional code – used in bands 5 and 6 in addition to state and territory codes – is based on principal port names, such as Boston (BOS), Seattle (SEA), and Ketchikan (KTN).

These three-character port identifiers are from the [UN LOCODE Code List by Country and Territory](#).

The final two characters of the ENC file name indicate a cell's position within its region's matrix of cells. The cell in the southwestern corner of each region is designated as "AA." The first letter of the pair is incremented for each additional cell moving northward and the second letter is incremented for each additional cell moving eastward in the matrix, as shown in Figure 7. Each region can hold a maximum of 676 cells in the 26 x 26 matrix.

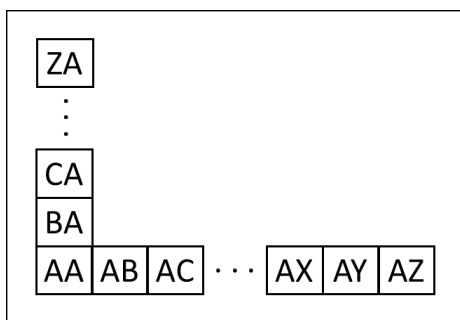
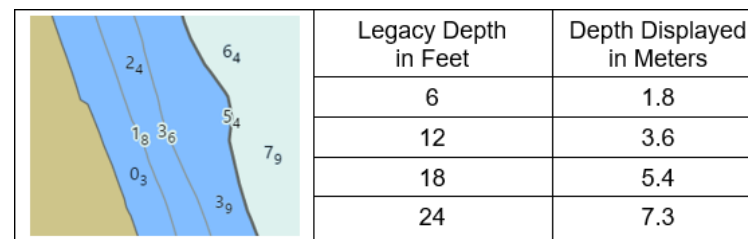

Figure 7.7. The last two characters in an ENC name describe a cell's position within its region.

Standardized metric depth contours

When NOAA digitized paper charts to create the first NOAA ENCs, depth values for soundings, depth curves, and other features with depths were converted from the fathoms and feet shown on the charts to meters, to populate the ENC database. The ENC product specification established by the IHO requires depths to be stored as metric values. However, depth contours continued to reflect the intervals in which they were originally compiled. Thus, depth contours in older ENC data displayed in meters will show fractional metric values resulting from the unit conversion from feet to meters, as shown in the image below.

Figure 7.8. Example of depth contours compiled in feet and displayed in meters.



When the ENC rescheming project is complete, all depth contours will be compiled in whole metric units. However, most newly reschemed ENC cells will not be recomputed their initial release (first edition) of the cell. The image below shows examples of whole 2, 5, 10, 20, and 50-meter depth contours. The depth value of soundings will also be stored and displayed with a higher degree of precision than available on paper charts. Soundings less than 30 meters deep are stored and displayed as meters with subscripts in tenths of meters (decimeters) – a granularity smaller than 4 inches.

Figure 7.9. Depiction of metric ENC depth contours.

Table 7.3 shows the standard depth contours that may be used in reschemed ENCs for each usage band. These are based on depth intervals specified in the IHO S-101 ENC Product Specification ("Depth area" section of the IHO S-101, ENC Product Specification, Annex A, Data Classification and Encoding Guide). Intervals used for a particular ENC will be based on the relief found within that cell. For larger scale ENCs, depth contours for 3, 4, 6, 7, and 8 meters will only be compiled in areas with a gently sloping bottom. In areas with extremely steep bathymetry, the 2 and 5 meter contours may also be omitted.

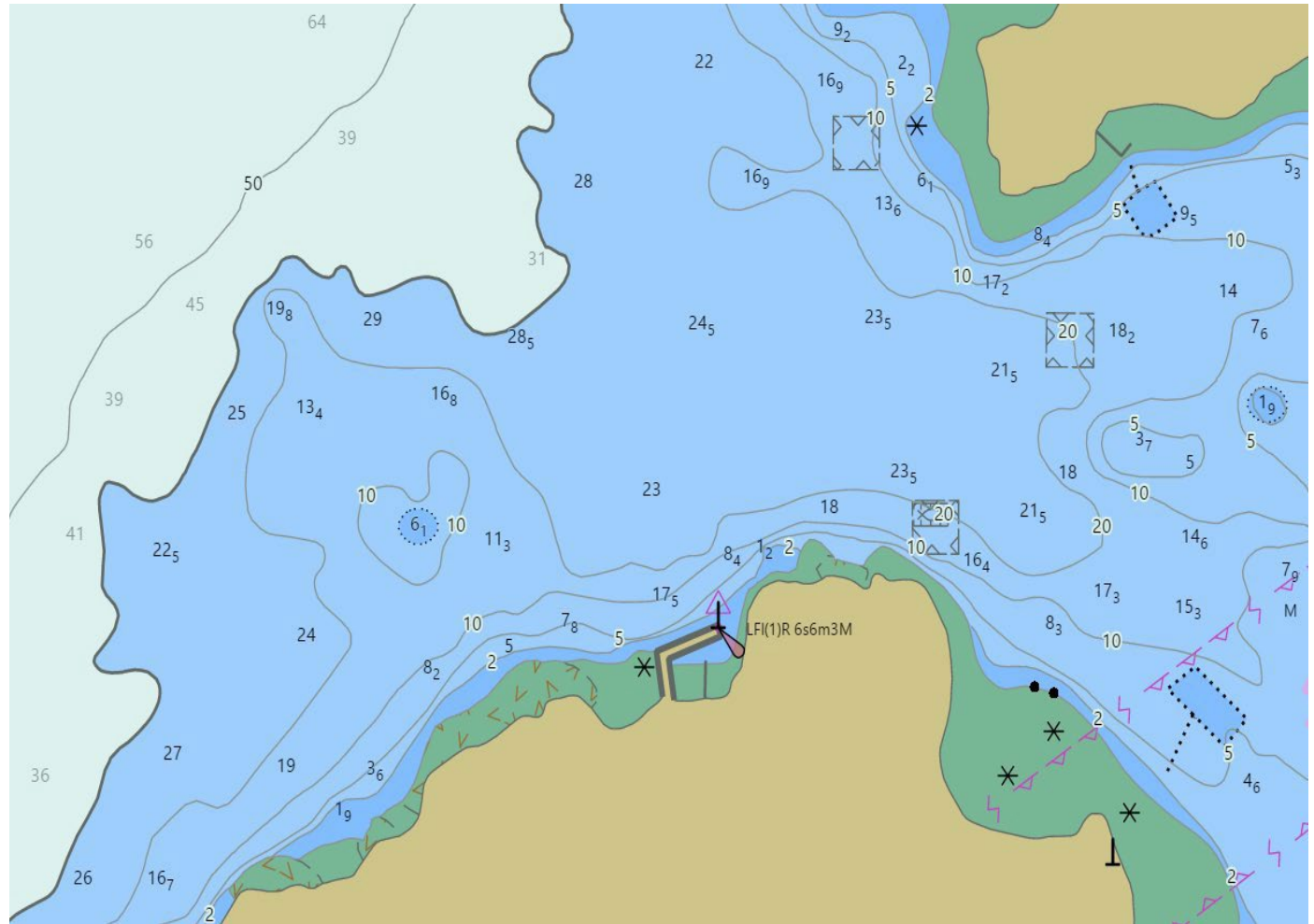

Table 7.3. Standard Metric Depth Contour Intervals. Optional values are shown in gray.

U.S.C.G AUXILIARY D7 GUIDE TO NOAA NAUTICAL CHARTS

Usage Band	Navigational Purpose	Compilation Scale	Depth Contours (meters)
1	Overview	1:10,000,000	100 200 300 400 500
		1:3,500,000	50 100 150 200 300 400 500
2	General	1:1,500,000	50 100 150 200 300 400 500
		1:700,000	20 50 100 150 200 300 400 500
3	Coastal	1:350,000	20 30 50 100 150 200 300 400 500
		1:180,000	10 20 30 50 100 150 200 300 400 500
4	Approach	1:90,000	5 10 15 20 30 50 100 150 200 300 400 500
		1:45,000	2 5 10 15 20 30 50 100 150 200 300 400 500
5	Harbor	1:22,000	2 5 10 15 20 30 50 100 150 200 300 400 500
		1:12,000	2 3 4 5 6 7 8 10 15 20 30 50 100 150 200 300 400 500
6	Berthing	1:4,000	2 3 4 5 6 7 8 10 15 20 30 50 100 150 200 300 400 500
		1:2,000	2 3 4 5 6 7 8 10 15 20 30 50 100 150 200 300 400 500

Annex A, at the end of this document, lists the regional codes.

11. NATIONAL CHARTING PLAN

As described in the NOAA ENC Design Scheme, the plan is to replace the haphazard charting that resulted from using RNC charts to generate the first generation of ENC, with a systematic rectangular grid of ENCs. This is outlined in NOAA’s National Charting Plan. The NOAA website maintains a page that displays the progress in creating the new ENC charts. A part of that page, displaying Florida as of September 12, 2024, is shown below.

This interactive map show progress being made in gridding the NOAA ENC product suite, as described in the [Nautical Charting Plan](#).

The layer list shows each usage band's status as:

- Completed
- Final Quality Check
- In Work
- Planned

- **Completed** = ENCs released to the public in gridded, standard scale cells. Other ENC improvements, such as the metrification of depths, and addition of topographic contours and transportation networks may not yet be present.
- **Final Quality Check** = ENCs undergoing final quality checks at IC-ENC
- **In Work** = ENCs actively being created
- **Planned** = new ENCs planned to be

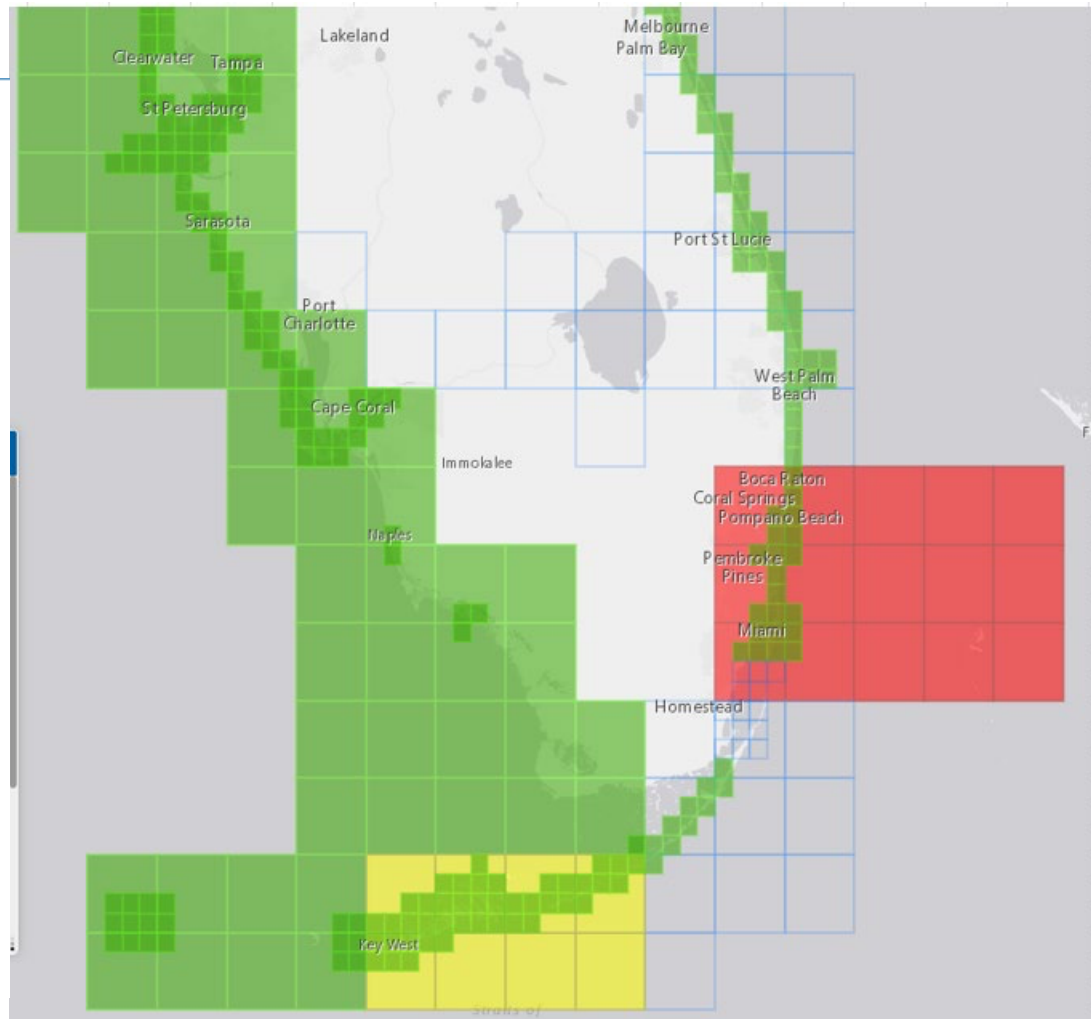

12. CHART UPDATES

Available updates are applied to ENC charts weekly. Recreational chart plotters are proprietary, and updates are available on the manufacturer's timetable. ECDIS systems and many charting apps allow downloading the weekly updates from NOAA.

Critical Updates

NOAA's Office of Coast Survey website maintains a list of what it deems critical updates to ENC charts. As an example, an update from 8/27/2024 shows that the Boca Raton Inlet South Jetty Light 1 has been relocated and provides the original and corrected positions. A note on the website advises that while critical corrections are made to NOAA ENCs, it may take up to 10 days before an update listed on the site is published. Corrections that have not yet been published will not appear in the NOAA ENC Viewer or on charts created by the NOAA Custom Chart. Corrections may not show on smaller scale (less detailed) charts.

13. CHART RESOLUTION

Paper

The resolution of charts printed by NOAA-authorized vendors is approximately 2000 dpi. However, lines and symbols on the chart must be large enough to see. The thinnest usable line on a paper chart is 0.1 mm, which NOAA uses for depth curves. 0.15 mm is used for man-made shoreline and thicker lines for natural shoreline. On a 1:40,000 chart, a 0.15 mm line is about 20 feet wide. On a 1:80,000 chart it is 39 ft. The base of the symbol for a lighted buoy on a 1:40,000 chart covers a circle over 300 feet in diameter. Contrast that with a GPS that can determine location within 10 – 30 feet.

RNC

NOAA RNC charts (since 2014) were produced at 400 dpi. The original scan is at higher resolution (762 dpi) but that is reduced to make the files sizes manageable. Not only does this lower than the resolution relative to the original, but it also creates a problem when a detail on the paper chart, such as a line or a color, falls part way across a pixel in the scan. To maintain accuracy would require doubling the pixel count in the scan. Since this is not practical (due to the resulting file size), software is used to increase the apparent resolution of the RNC chart by shifting the details.

Since an RNC chart does not have the resolution of a paper chart, it must be displayed at higher zoom (typically 1.5 x) to view the details. This means the chart is being used at a larger scale than the compilation (original) scale, which creates an illusion of accuracy.

Another issue arises from displaying an RNC chart on a screen. The latest high-end recreational marine chart plotters with a 12.1 in. diagonal screen have WXGA resolution, meaning 133 dpi horizontal x 86 dpi vertical. The resulting pixel size is 0.056 mm² compared to the 0.004 mm² pixels on the 400 dpi raster chart. These are typical values. If 1 pixel on the display is used to represent 1 pixel on the RNC chart, the resulting

display will be 14 times larger than the chart. To view the chart on the display at the same size as the original requires dropping 90% of the pixels. This is achieved with software that decides what to drop and generates an on-screen facsimile of the original that is much lower resolution.

As the image is zoomed, the number of pixels on the screen remains constant, but each is asked to represent fewer pixels from the original. All is well and resolution increases until the zoom passes the point at which a pixel on the screen represents less than 1 pixel on the original. There is not enough data to draw the screen accurately and the image is over zoomed. Some chart displays alert the user to over zooming, but not all have that feature. Even without an alert, the fact that the symbols and text have become exceptionally large is a sign that the chart is over zoomed.

ENC

IHO S-52 defines the minimum resolution of an ECDIS (not recreational) display and the sizes of ENC symbols. The standard specifies minimum screen resolution and size. The minimum screen size is 270 x 270 mm (10.63 x 10.63 in.) That size must have at least 864 rows with a pixel height of 0.312 mm.

The smallest line weight that will be represented is 0.3 mm. Using OpenCPN on a 1080p display, at 1:40,000 the 0.3 mm line is about 13 ft. wide. The basic symbol (simplified symbols) for a buoy is about 90 ft. wide. Bear in mind, when the display says the scale is 1:40,000, it will actually be showing a larger scale for clarity. Generally, the symbols on an ENC chart occupy less space than on an RNC.

By tradition and to be legible, symbols on nautical charts are larger than the real-world features they represent. This remains true for ENC charts, which are prepared with a compilation scale the is the maximum intended viewing scale on a display. When the ENC is displayed at scales increasingly larger than the compilation scale, the relationship between the point symbol and the feature it represents breaks down. As scale increases, the symbol represents a progressively smaller portion of the real-world feature. This can lead to the impression that navigation close to the point symbol is safe because there appears to be open water around the shrunken symbol.

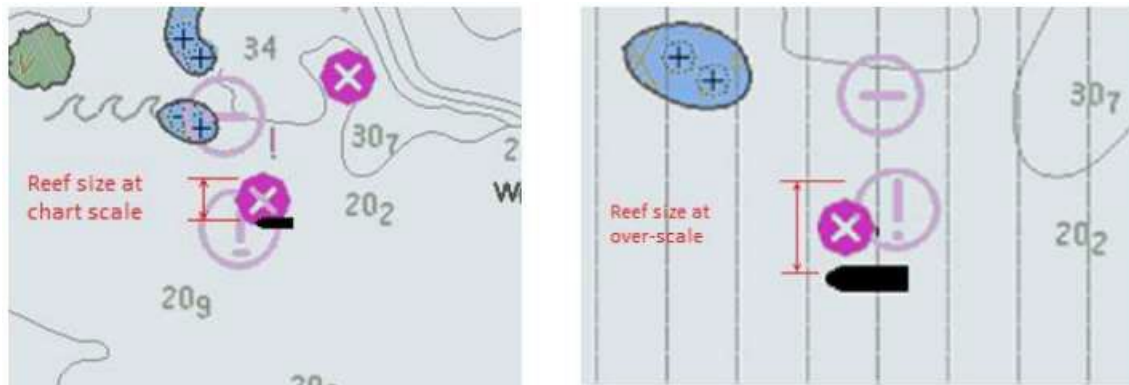

In the left image, shown at intended scale, passing close to the charted reef is clearly unsafe. In the right, over-scaled image, passing at the same

distance appears safe. The symbol did not change size as the display zoomed so it no longer fully covers the reef. A detailed explanation of over scaling on ENC charts can be found in IHO Publication *Information on ENC Generalization, Over-Scaling and Safety Checking Functions in ECDIS (2020)*. While this document is aimed at ocean-going shipping, the discussion of chart accuracy and GPS is useful to all mariners.

14. CHART SYMBOLS













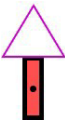



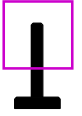
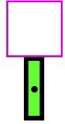

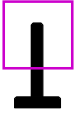
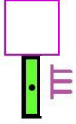
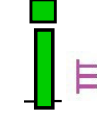
NOAA Paper and RNC charts use a standard set of symbols which can be found in U.S Chart No. 1 *Symbols, Abbreviations and Terms used on Paper and Electronic Navigational Charts* (see U.S. Chart No. 1 below).

NOAA Electronic charts have two sets of symbols – so-called Paper and Simplified. These are defined in IHO S-52. In addition, recreational-grade chart plotters use a variety of proprietary adaptations of the S-52 symbols. Depending on the chart software used, it may be possible to switch between the paper and simplified symbol sets.

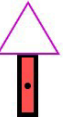
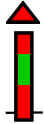
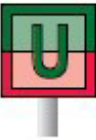

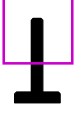
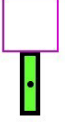



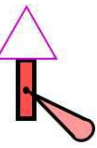
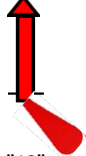





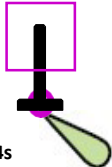
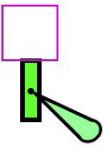



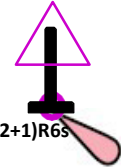
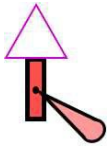
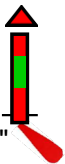

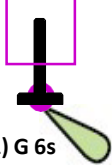
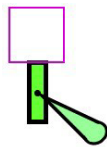
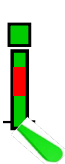





Consulting U.S. Chart No. 1, the reader will find that every symbol on a paper or RNC chart is fully described therein, with an image that corresponds exactly to what is found on the chart. ENC symbols are composites of base symbols. So, the symbol of a minor beacon has one symbol for the beacon, to which is added the symbol for the dayboard. If the beacon is lighted, another symbol is added to show the light, and so on. This makes it more challenging for those used to paper charts to understand ENC symbols because there is no corresponding guide. This section is intended to address that issue by showing the most common chart symbols for paper/RNC alongside the “Paper” and Simplified ENC symbols. In addition, the symbols used by Navionics, one of the proprietary systems, are shown for comparison.

Another source of ENC symbols is the IHO S-52 Annex A: IHO ECDIS Presentation Library. This document is available at no charge online.





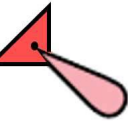









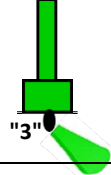









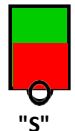

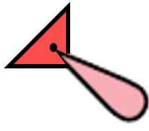
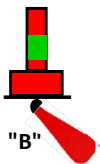

U.S.C.G AUXILIARY D7 GUIDE TO NOAA NAUTICAL CHARTS

AID TYPE	IMAGE	NOAA RNC CHART	ENC "Paper"	ENC "Simplified"	Navionics
RED BEACON		 R "4"	 "4"	 "4"	 "4"
GREEN BEACON		 G "3"	 "3"	 "3"	 "3"
RETRO-REFLECTORON BEACON			 "3"	 "3"	 "3"
RED OVER GREEN PREFERRED CHANNEL / JUNCTION BEACON		 RG "G"	 "G"	 "G"	 "G"
GREEN OVER RED PREFERRED CHANNEL / JUNCTION BEACON		 GR "U"	 "U"	 "U"	 "U"
LIGHTED RED BEACON		 "12" Fl(2+1) R 6s	 12" Fl(2+1) R 6s	 "12"	 "12"

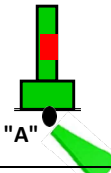



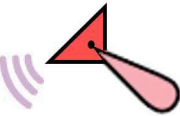







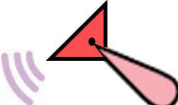



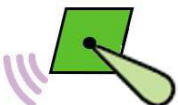
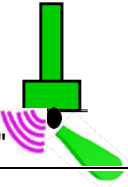



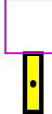

U.S.C.G AUXILIARY D7 GUIDE TO NOAA NAUTICAL CHARTS

AID TYPE	IMAGE	NOAA RNC CHART	ENC "Paper"	ENC "Simplified"	Navionics
LIGHTED GREEN BEACON		 "5" Fl G 4s	 "5" Fl(1)G4s		 "5"
LIGHTED RG PREFERRED CHANNEL / JUNCTION BEACON		 RG "G" Fl(2+1) R 6s	 "G" Fl(2+1)R6s		 "G"
LIGHTED GR PREFERRED CHANNEL / JUNCTION BEACON		 GR "U" Fl(2+1) G 6s	 "U" Fl(2+1) G 6s		 "U"
NUN BUOY		 R N "4"			 "4"
CAN BUOY		 G C "5A"	 "5A"		 "5A"
LIGHTED RED BUOY		 R "10" Fl R 4s	 "10" Fl R 4s		 "10"

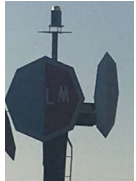

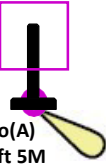
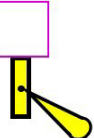
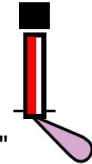



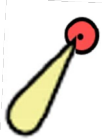
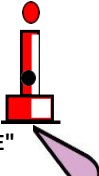











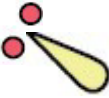







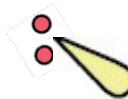

U.S.C.G AUXILIARY D7 GUIDE TO NOAA NAUTICAL CHARTS

AID TYPE	IMAGE	NOAA RNC CHART	ENC "Paper"	ENC "Simplified"	Navionics
LIGHTED GREEN BUOY		 <i>G "3" FIG 4s</i>	 <i>"3" FIG 4s</i>		 <i>"3"</i>
PREFERRED CHANNEL / BIFURCATON / JUNCTION BUOY		 <i>RG N "C"</i>	 <i>"C"</i>		 <i>"C"</i>
PREFERRED CHANNEL / BIFURCATON / JUNCTION BUOY		 <i>GR C "S"</i>	 <i>"S"</i>		 <i>"S"</i>
LIGHTED PREFERRED CHANNEL / BIFURCATON / JUNCTION BUOY		 <i>RG "B" FI(2+1) R 6s</i>	 <i>"B" FI(2+1) R 6s</i>		 <i>"B"</i>
LIGHTED PREFERRED CHANNEL / BIFURCATON / JUNCTION BUOY		 <i>GR "A" FI(2+1) G 6s</i>	 <i>"A" FI(2+1) G 6s</i>		 <i>"A"</i>
LIGHTED WHISTLE BUOY (May be G or R)		 <i>R "2V" FI R 2.5s</i>	 <i>"2V" FI R 2.5s WHIS</i>		 <i>"2V"</i>



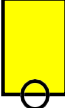



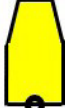





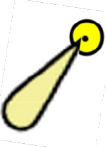
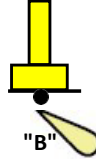

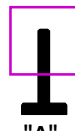
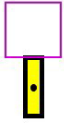

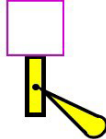
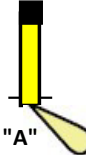

U.S.C.G AUXILIARY D7 GUIDE TO NOAA NAUTICAL CHARTS

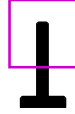
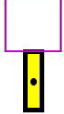
AID TYPE	IMAGE	NOAA RNC CHART	ENC "Paper"	ENC "Simplified"	Navionics
LIGHTED BELL BUOY (May be G or R)		 R "8" FI R 2.5s BELL	 "8" FI R 2.5s BELL		 "8"
LIGHTED GONGBUOY (May be G or R)		 G "29" FI G 2.5s GONG	 "29" FI G 2.5s GONG		 "29"
SAFE WATER MARK BEACON		 RW "N"	 "N"		 "N"
SAFE WATER MARK / MID- CHANNEL / FAIRWAY BUOY		 RW "E"	 "E"		 "E"
LIGHTED SAFEWATER MARK BEACON		 RW "LM" Mo (A) 16ft 5M	 "LM" Mo(A) W 8s 16ft 5M		 "LM"
LIGHTED SAFEWATER MARK BUOY		 RW "PE" Mo (A) 18ft 5M	 "PE" Mo(A) W 8s 18ft 5M		 "PE"

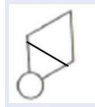





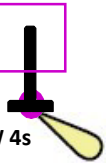
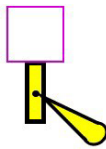
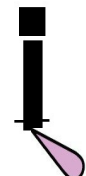









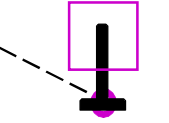
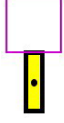





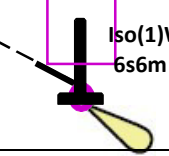
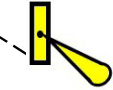

U.S.C.G AUXILIARY D7 GUIDE TO NOAA NAUTICAL CHARTS

AID TYPE	IMAGE	NOAA RNC CHART	ENC "Paper"	ENC "Simplified"	Navionics
ISOLATED DANGER MARK BUOY		 BR "C"	 "C"		 "C"
LIGHTED ISOLATED DANGER MARK BUOY		 BR "DP" Fl (2) 5s	 "DP" Fl(2)W5s		 "DP"
ISOLATED DANGER MARK BEACON		 BR			
LIGHTED ISOLATED DANGER MARK BEACON		 BR Fl (2) 5s	 Fl(2)W5s		
SPECIAL PURPOSE CANBUOY		 YC "A"	 "A"		 "A"
SPECIAL PURPOSE NUNBUOY		 YN "C"	 "C"		 "C"

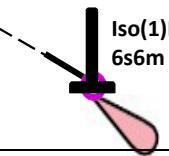
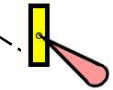

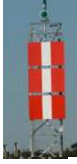

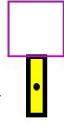



















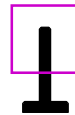

U.S.C.G AUXILIARY D7 GUIDE TO NOAA NAUTICAL CHARTS



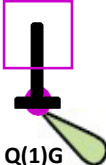
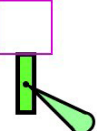





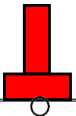



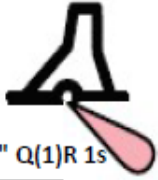









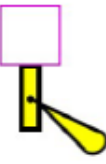





AID TYPE	IMAGE	NOAA RNC CHART	ENC "Paper"	ENC "Simplified"	Navionics
LIGHTED SPECIAL PURPOSE BUOY		 Y "B" Fl Y	 B" Fl(1) Y 6s		 "B"
SPECIAL PURPOSE BEACON	 Y "A" Bn	 Y "A" Bn	 "A"		 "A"
LIGHTED SPECIAL PURPOSE BEACON	 Y "A" Fl Y W Or	 Y "A" Fl Y W Or	 "A" Fl Y		 "A"
REGULATORY / DANGER BEACON	 W Bn	 W Bn	 "A"		
REGULATORY / DANGER BUOY	 W Bn	 W Bn	 W Bn		
LIGHTED REGULATORY / DANGER BEACON	 Fl W 4s	 Fl W 4s	 Fl W 4s		

U.S.C.G AUXILIARY D7 GUIDE TO NOAA NAUTICAL CHARTS

AID TYPE	IMAGE	NOAA RNC CHART	ENC "Paper"	ENC "Simplified"	Navionics
LIGHTED REGULATORY / DANGER BUOY		 FI 4s	 FI W 4s		
RANGE MARK On Pile With Board Narrow Light		 FI W 2.5s 20ft	 FI(1)W 2.5s6m		
RANGE MARK On Pile No Board Narrow Light		 FI W 2.5s 20ft	 FI(1)W 2.5s6m		
RANGE MARK On Pile No Board 360° White Light		 Iso W 6s 20ft	 Iso(1)W 6s6m		
RANGE MARK On Pile No Board 360° Red Light		 Iso R 6s 20ft	 Iso(1)R 6s6m		
RANGE MARK Skeleton Tower With Board Narrow Light		 FI W 2.5s 20ft	 FI(1)W 2.5s6m		

U.S.C.G AUXILIARY D7 GUIDE TO NOAA NAUTICAL CHARTS

AID TYPE	IMAGE	NOAA RNC CHART	ENC "Paper"	ENC "Simplified"	Navionics
RANGE MARK Skeleton Tower No Board Narrow Light		 FI W 2.5s 20ft	 FI(1)W 2.5s6m		
RANGE MARK Skeleton Tower No Board 360° White Light		 Iso W 6s 20ft	 Iso(1)W 6s6m		
RANGE MARK Skeleton Tower No Board 360° Red Light		 Iso R 6s 20ft	 Iso(1)R 6s6m		
WRECK MARK BEACON (May be G or R)		 G "3WR"	 "3WR"		 "3WR"
LIGHTED WRECK MARK BEACON (May be G or R)		 "3WR" QG	 "3WR" Q(1)G		 "3WR"
WRECK MARK BUOY (May be G or R)		 "WR"	 "WR"		 "WR"

AID TYPE	IMAGE	NOAA RNC CHART	ENC "Paper"	ENC "Simplified"	Navionics
LIGHTED WRECK MARK (May be G or R)		 <i>R "WR" QR</i>	 "WR" Q(1)R 1s		 "WR"
LOCATION MARK		 RW Bn			
LIGHTED LOCATION MARK		 Fl (1) W 4s			
PIER LIGHT					
MAJOR LIGHT		 Fl 15s 85ft 24M			
AIS or RACON		 <i>RACON (-)</i>			

15. KEY FEATURES OF PAPER CHARTS**Title Block**

The title block on a paper chart contains key information and important notes.

1. The geographic region in which the area covered by the chart is located.
2. The Title of the chart which is a more specific location description.
3. The chart projection – in this case Mercator.
4. The chart scale and the latitude at which the projection has no distortion.
5. The horizontal datum. In this case NAD83, which is equivalent to WGS84.
6. The units of depth measurement – in this case FEET.
7. The vertical datum – depth is relative to Mean Lower Low Water.
8. The vertical datum for heights and clearances, Here it is relative to Mean High Water.

Colors

- Land areas are buff or yellowish in color.
- Water is white.
- Shallow water is light blue.
- Areas which uncover at low tide are green.
- Magenta is used for several things. Lighted buoys of any color have a magenta disc around the position circle.
- Aids to navigation are red or green.
- Most text and symbols are black.

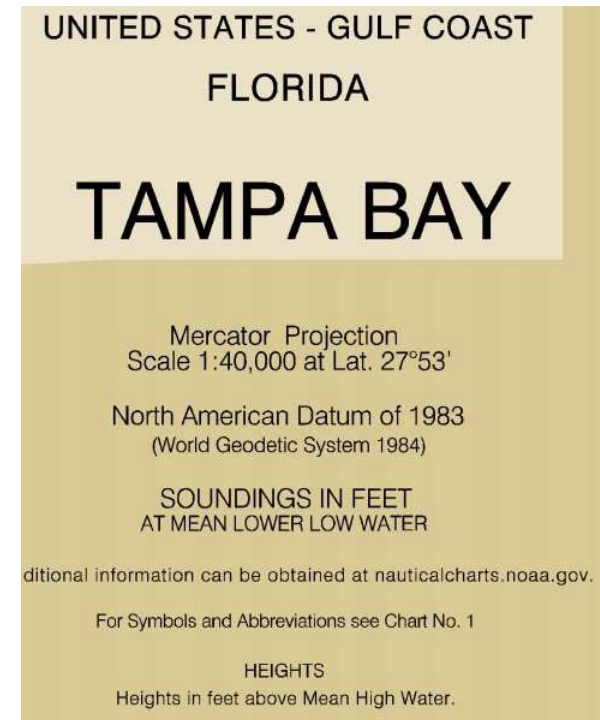

Chart Number, Edition, Date of Last Correction

The lower left corner of the chart also has important information:

1. The chart number.
2. The data of the Local Notice to Mariners from which the chart was corrected.
3. A disclaimer that ENC charts are updated more frequently.
4. The edition, date, and last correction date of the chart.
5. A 6-inch line which can be checked to verify that the chart was printed to the correct scale.

11006

CAUTION

This chart has been corrected from the Notice to Mariners (NM) published weekly by the National Geospatial-Intelligence Agency and the Local Notice to Mariners (LNM) issued periodically by each U.S. Coast Guard district to the dates shown in the lower left hand corner. Chart updates corrected from Notice to Mariners published after the dates shown in the lower left hand corner are available at nauticalcharts.noaa.gov.

Use NOAA electronic navigational charts for the most up-to-date information.

34th Ed., Aug. 2013. Last Correction: 4/30/2021. Cleared through:

LNM: 1421 (4/6/2021), NM: 1821 (5/1/2021)

To ensure that this chart was printed at the proper scale, the line below should measure six inches (152 millimeters).

If the line does not measure six inches (152 millimeters), this copy is not certified safe for navigation.

Lettering

Topographic features and those attached to the sea bottom and above MHW have vertical lettering.

Features below MHW, names of bodies of water, underwater features, and all floating objects have italic lettering.

Depth Contours

Lines of constant depth (isobaths) are shown in black with the depth printed across the line at some point.

Latitude and Longitude

Latitude scales are printed on each side of the chart. Longitude scales are printed at the top and bottom. The scales are broken into minutes and tenths of a minute. Latitude values are read from right to left, longitude from bottom to top.

Always measure distance using the latitude scale at the same latitude as the measurement is being taken. One minute of latitude equals 1 nautical mile.

Compass Rose

Compass roses are printed in multiple places on the chart. The outer circle represents true degrees (North and South orientation based on the earth's axis of rotation around a line running between the North and South Poles.) The inner circle represents the local magnetic direction as of the date printed in the center of the compass rose.

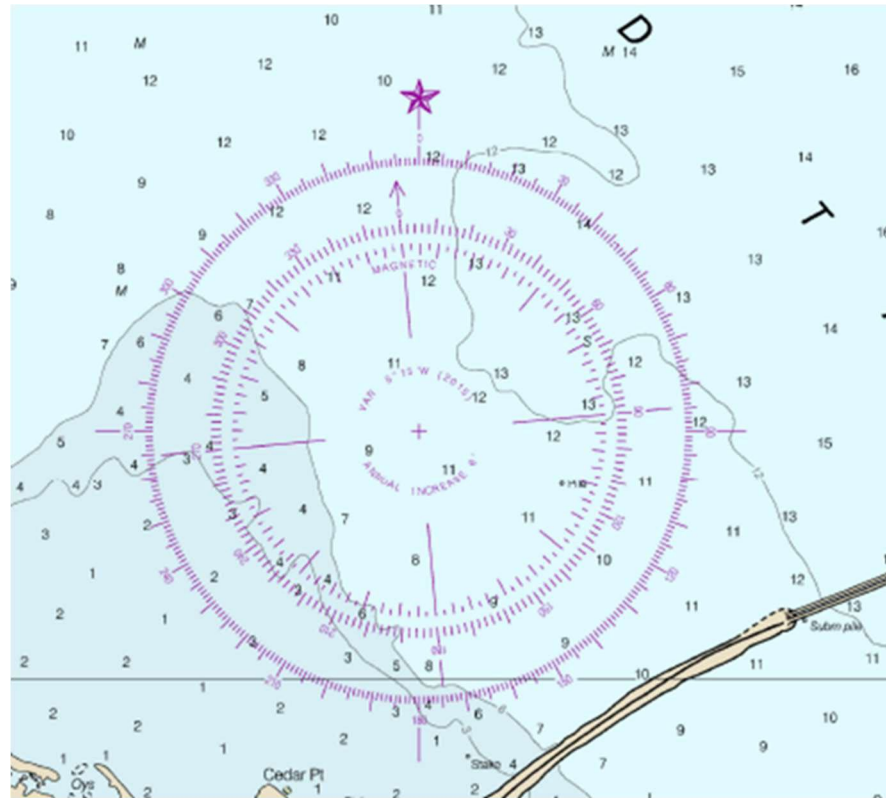

Paper charts are always printed so that True North is up.

10. U.S. CHART NO. 1

U.S. Chart No. 1. is the complete guide to nautical charts. It is available in pdf format at no charge from NOAA. A printed version can also be purchased from any marine supplier or online.

This is an indispensable reference for anyone using nautical charts.

Chart No. 1 covers:

- NOAA paper/RNC charts of U.S. waters
- NGA (National Geospatial /Intelligence Agency) charts of the world
- INT (International) charts
- ECDIS (ENC) charts.

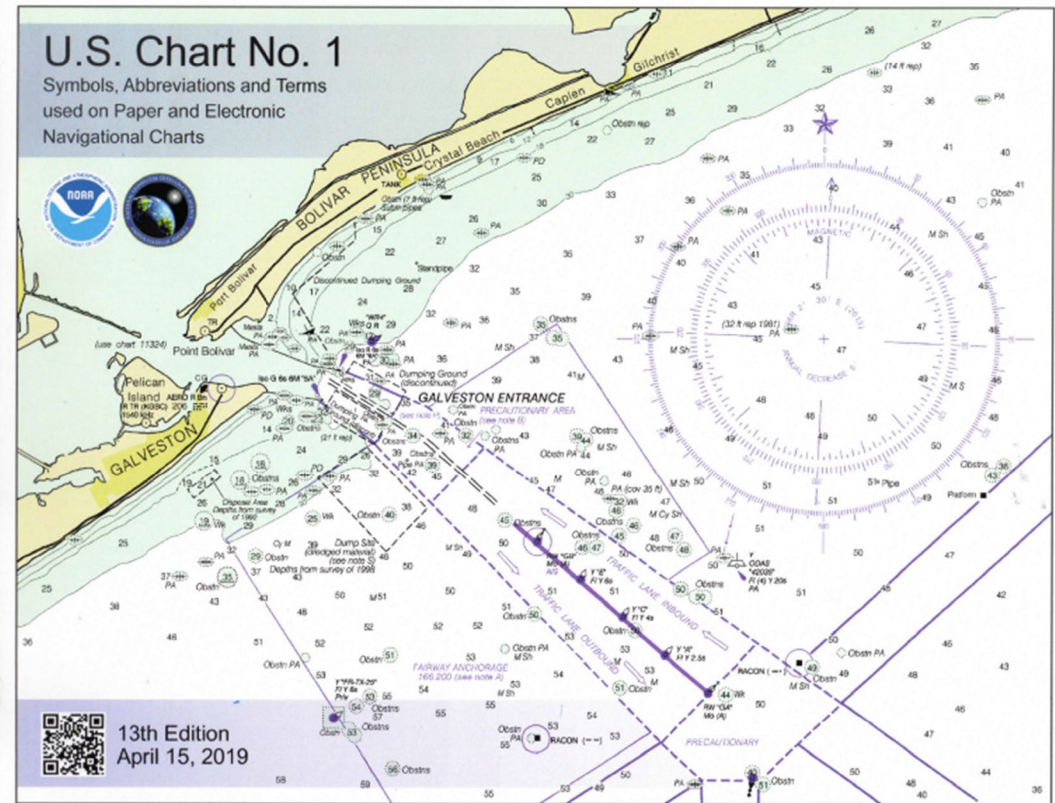

U.S. Chart No. 1

Symbols, Abbreviations and Terms
used on Paper and Electronic Navigational Charts

13th Edition
April 15, 2019

Prepared Jointly by

Department of Commerce
National Oceanic and Atmospheric Administration

Department of Defense
National Geospatial-Intelligence Agency

Chart No. 1 is organized in sections as shown on the next page.

A		Chart Number, Title and Marginal Notes	INT 500 412 Mercator Projection Scale 1:100,000 at Lat. 59°30' 53rd Ed., Feb. 2019 DEPTHS IN METERS
B		Positions, Distances, Directions and Compass	±15° Magnetic Variation 4°30'W 2011 (8'E) LOCAL MAGNETIC ANOMALY (see note)
C		Natural Features	
D		Cultural Features	 FIXED BRIDGE HOR CL 25 FT VERT CL 20 FT
E		Landmarks	
F		Ports	
H		Tides and Currents	
I		Depths	
J		Nature of the Seabed	
K		Rocks, Wrecks and Obstructions	
L		Offshore Installations	
M		Tracks and Routes	
N		Areas and Limits	
P		Lights	
Q		Buoys and Beacons	
R		Fog Signals	
S		Radar, Radio and Satellite Navigation Systems	
T		Services	
U		Small Craft (Leisure) Facilities	

U.S. Chart No. 1 Certificate of Authenticity
 U.S. Chart No. 1, Symbols, Abbreviations and Terms used on Paper and Electronic Navigational Charts is prepared jointly by the National Oceanic and Atmospheric Administration (NOAA) and the National Geospatial-Intelligence Agency (NGA). It is the authoritative source of information on U.S. nautical chart symbology. This copy of U.S. Chart No. 1 was printed and distributed under the authority of NOAA and is an official publication of NOAA and NGA.

PREPARED BY
PARADISE CAY
PUBLICATIONS
 P.O. Box 29 • Arcata, CA 95518-0029
 (800) 736-4509 • (707) 822-9063
 orders@paracay.com • www.paracay.com

ISBN 978-1-937196-29-5

 90000

Key References for ENC Chart

- NOAA Office of Coast Survey – Marine Chart Division
 - Nautical Charting Plan August 2023
 - NOAA ENC Design Handbook August 2023
- NOAA Office of Coast Survey – Hydrographic Survey Division
 - Hydrographic Survey Specifications and Deliverables
 - Field Procedures Manual
- IHO S-4 Regulations for International Charts and Chart Specifications of the IHO
- IHO S-11 Guidance for the Preparation and Maintenance of International Chart and ENC Schemes and Catalog of International Charts.
- IHO S-12 Standardization of List of Lights and Fog Signals
- IHO S-44 IHO Standards for Hydrographic Surveys
- IHO S-52 Specifications for Chart Content and Display Aspects of ECDIS
 - Annex A IHO ECDIS Presentation Library
 - Annex A Addendum Symbol Library for Use on ECDIS
- IHO S-57 IHO Standard for Digital Hydrographic Data
- IHO S-58 ENC Validation Checks
- IHO S-60 User's Handbook on Datum Transformations involving WGS84
- IHO S-61 Product Specifications for Raster Navigational Charts
- IHO S-65 ENC's: Production, Maintenance and Distribution Guidance
- IHO S-101 Electronic Navigational Chart (ENC)

Annex A: Regional ENC Chart Codes from NOAA ENC Design Scheme June 2024

Some codes, especially in band 6, are not currently used (as of June 2024).

Region	Code	Band
Global	GLB	1

Region	Code	Band
Arctic	ARC	2
Antarctic	ANT	2
Atlantic	ATL	2
Great Lakes	GRL	2
Gulf of Mexico	GOM	2
Pacific	PAC	2

Region	Code	Band
Alaska	AK1	3
Alabama	AL1	3
American Samoa	AS1	3
California	CA1	3
Connecticut	CT1	3
Cuba	CU1	3
Florida	FL1	3
Georgia	GA1	3
Guam	GU1	3
Hawaii	HI1	3
Illinois	IL1	3
Indiana	IN1	3
Louisiana	LA1	3
Massachusetts	MA1	3
Maryland	MD1	3
Maine	ME1	3
Michigan	MI1	3
Minnesota	MN1	3
Mississippi	MS1	3
North Carolina	NC1	3
New Hampshire	NH1	3
New Jersey	NJ1	3
New York	NY1	3
Ohio	OH1	3
Oregon	OR1	3
Pennsylvania	PA1	3
Puerto Rico	PR1	3
Rhode Island	RI1	3
South Carolina	SC1	3
Texas	TX1	3
US Minor 1	UM1	3
US Minor 2	UM2	3
Virginia	VA1	3
Washington	WA1	3
Wisconsin	WI1	3

Region	Code	Band
Alaska 1	AK1	4
Alaska 2	AK2	4
Alaska 3	AK3	4
Alaska 4	AK4	4
Alaska 5	AK5	4
Alaska 6	AK6	4
Alaska 7	AK7	4
Alabama	AL1	4
American Samoa	AS1	4
Antarctic Treaty 1	AQ1	4
Antarctic Treaty 2	AQ2	4
California 1	CA1	4
California 2	CA2	4
Connecticut	CT1	4
Delaware	DE1	4
Florida 1	FL1	4
Florida 2	FL2	4
Georgia	GA1	4
Guam 1	GU1	4
Guam 2	GU2	4
Hawaii 1	HI1	4
Hawaii 2	HI2	4
Hawaii 3	HI3	4
Hawaii 4	HI4	4
Idaho	ID1	4
Illinois	IL1	4
Indiana	IN1	4
Louisiana	LA1	4
Massachusetts	MA1	4
Maryland	MD1	4
Maine	ME1	4
Michigan 1	MI1	4
Michigan 2	MI2	4
Minnesota	MN1	4
Mississippi	MS1	4
North Carolina	NC1	4
New Hampshire	NH1	4
New Jersey	NJ1	4
Nevada 1	NV1	4
Nevada 2	NV2	4
New York 1	NY1	4
New York 2	NY2	4
Ohio	OH1	4
Oregon	OR1	4
Pennsylvania	PA1	4
Puerto Rico	PR1	4

Region	Code	Band
Rhode Island	RI1	4
South Carolina	SC1	4
Texas	TX1	4
US Minor 1	UM1	4
US Minor 2	UM2	4
US Minor 3	UM3	4
US Minor 4	UM4	4
US Minor 5	UM5	4
US Minor 6	UM6	4
Virginia	VA1	4
Virgin Islands	VI1	4
Washington	WA1	4
Wisconsin	WI1	4

Region	Code	Band
Alaska 11	A1K	5
Alaska 12	A2K	5
Alaska 13	A3K	5
Alaska 14	A4K	5
Alaska 10	AK0	5
Alaska 1	AK1	5
Alaska 2	AK2	5
Alaska 3	AK3	5
Alaska 4	AK4	5
Alaska 5	AK5	5
Alaska 6	AK6	5
Alaska 7	AK7	5
Alaska 8	AK8	5
Alaska 9	AK9	5
Alabama	AL1	5
Anchorage, AK	ANC	5
Alpena, MI	APN	5
New Iberia, LA	ARA	5
American Samoa 1	AS1	5
American Samoa 2	AS2	5
American Samoa 3	AS3	5
Antarctic Treaty	AQ1	5
Baltimore, MD	BAL	5
Bridgeport, CT	BDR	5
Bangor, ME	BGR	5
Biloxi, MS	BIX	5
Boston, MA	BOS	5
Baton Rouge, LA	BPG	5
Beaumont, TX	BPT	5
Brownsville, TX	BRO	5
Buffalo, NY	BUF	5
California 1	CA1	5
California 2	CA2	5
California 3	CA3	5

Region	Code	Band
California 4	CA4	5
California 5	CA5	5
California 6	CA6	5
Conneaut, OH	CDY	5
Chicago, IL	CHI	5
Charleston, SC	CHS	5
Cleveland, OH	CLE	5
Port Angeles, WA	CLM	5
Coos Bay, OR	COB	5
Corpus Christi, TX	CRP	5
Connecticut	CT1	5
District of Columbia	DC1	5
Delaware	DE1	5
Detroit, MI	DET	5
Duluth, MN	DLH	5
Drummond Island, MI	DRE	5
Escanaba, MI	ESC	5
Fall River, MA	FAV	5
Florida 1	FL1	5
Florida 2	FL2	5
Florida 3	FL3	5
Florida 4	FL4	5
Florida 5	FL5	5
Florida 6	FL6	5
Florida 7	FL7	5
Florida 8	FL8	5
Fond du Lac, WI	FLD	5
Flemington, NJ	FLE	5
Flatrock, MI	FLF	5
Foley, FL	FLS	5
Flat, AK	FLT	5
Franklin, WI	FLW	5
Fort Bragg, CA	FOB	5
Fourchon, LA	FOC	5
Freeport, TX	FPO	5
Fairport Harbor, OH	FPT	5
Georgia 1	GA1	5
Georgia 2	GA2	5
Grays Harbor, WA	GHC	5
Gulfport, MS	GPT	5
Green Bay, WI	GRB	5
Guam 1	GU1	5
Guam 2	GU2	5
Guam 3	GU3	5
Guam 4	GU4	5
Gulliver, MI	GUV	5
Hempstead, NY	HEP	5
Hingham, MT	HGG	5
Hawaii 1	HI1	5

Region	Code	Band
Hawaii 2	HI2	5
Hawaii 3	HI3	5
Hawaii 4	HI4	5
Hawaii 5	HI5	5
Hawaii 6	HI6	5
Hawaii 7	HI7	5
Hawaii 8	HI8	5
Honolulu, HI	HNL	5
Houston, TX	HOU	5
Hopewell, VA	HPW	5
Houma, LA	HUM	5
New Haven, CT	HVN	5
Illinois	IL1	5
Wilmington, DE	ILG	5
Wilmington, NC	ILM	5
Ithaca, NY	ITH	5
Hilo, HI	ITO	5
Jacksonville, FL	JAX	5
Juneau, AK	JNU	5
Lakeside Marblehead, OH	KDB	5
Kinsman, IL	KFM	5
Kawaihae, HI	KHW	5
Ketchikan, AK	KTN	5
Kivalina, AK	KVL	5
Louisiana 1	LA1	5
Louisiana 2	LA2	5
Louisiana 3	LA3	5
Laguna Beach, CA	LAX	5
Lancaster, NY	LAC	5
La Mesa, CA	LAE	5
Lake Charles, LA	LCH	5
Long Beach, CA	LGB	5
Morgan City, LA	LMO	5
Lorain, OH	LOR	5
Port of South Louisiana, LA	LU8	5
Massachusetts	MA1	5
Maryland	MD1	5
Maine 1	ME1	5
Maine 2	ME2	5
Maine 3	ME3	5
Manatee, FL	MEE	5
Moffett Field, CA	MEF	5
Mehoopany, PA	MEH	5
Matagorda Island, TX	MGI	5
Michigan 1	MI1	5
Michigan 2	MI2	5
Michigan 3	MI3	5
Michigan 4	MI4	5
Michigan 5	MI5	5

Region	Code	Band
Michigan 6	MI6	5
Michigan 7	MI7	5
Miami, FL	MIA	5
Milwaukee, WI	MKE	5
Muskegon, MI	MKG	5
Minnesota	MN1	5
Mobile, AL	MOB	5
Morehead City, NC	MRH	5
Mississippi	MS1	5
New Orleans, LA	MSY	5
North Carolina 1	NC1	5
North Carolina 2	NC2	5
New Hampshire	NH1	5
Nawiliwili, HI	NIJ	5
New Jersey	NJ1	5
Nikishka, AK	NQK	5
Port Hueneme, CA	NTD	5
New York 1	NY1	5
New York 2	NY2	5
New York 3	NY3	5
New York 4	NY4	5
New York 5	NY5	5
New York 6	NY6	5
New York 9	NY9	5
New York City, NY	NYC	5
Oakland, CA	OAK	5
Kahului, HI	OGG	5
Olympia, WA	OLM	5
Oregon 1	OR1	5
Oregon 2	OR2	5
Norfolk, VA	ORF	5
Orange, TX	ORG	5
Pennsylvania	PA1	5
Palm Beach, FL	PAB	5
Pittsburg, CA	PBG	5
Port Canaveral, FL	PCV	5
Portland, OR	PDX	5
Port Everglades, FL	PEF	5
Panama City, FL	PFN	5
Pascagoula, MS	PGL	5
Philadelphia, PA	PHL	5
Plaquemine, LA	PLQ	5
Port Lavaca, TX	PLV	5
Pensacola, FL	PNS	5
Port Arthur, TX	POA	5
Puerto Rico 1	PR1	5
Puerto Rico 2	PR2	5
Ponce, PR	PSE	5
Portsmouth, NH	PSM	5

Region	Code	Band
Kawaihae , HI	KHW	6
Ketchikan, AK	KTN	6
Kivalina, AK	KVL	6
Laguna Beach, CA	LAX	6
Lake Charles, LA	LCN	6
Long Beach, CA	LGB	6
Longview, WA	LOG	6
Lorain, OH	LOR	6
Port of South Louisiana, LA	LU8	6
Marcus Hook, PA	MAH	6
Manatee, FL	MEE	6
Matagorda Island, TX	MGI	6
Calcite, MI	MI3	6
Miami, FL	MIA	6
Milwaukee, WI	MKE	6
Muskegon, MI	MKG	6
Mobile, AL	MOB	6
Monroe, MI	MOI	6
Marquette, MI	MQT	6
Morehead City, NC	MRH	6
New Orleans, LA	MSY	6
Barbers Point, Oahu, HI	NAX	6
New Castle, DE	NCD	6
Nawiliwili, HI	NIJ	6
Nikishka, AK	NQK	6
Port Hueneme, CA	NTD	6
New York City, NY	NYC	6
Oakland, CA	OAK	6
Kahului, HI	OGG	6
Olympia, WA	OLM	6
Norfolk, VA	ORF	6
Palm Beach, FL	PAB	6
Everett, WA	PAE	6
Paulsboro, NJ	PAU	6
Port Canaveral, FL	PCV	6

Region	Code	Band
Bangor, ME	BGR	6
Biloxi, MS	BIX	6
Burns Harbor, IN	BNB	6
Boston, MA	BOS	6
Baton Rouge, LA	BPG	6
Beaumont, TX	BPT	6
Brownsville, TX	BRO	6
Buffalo, NY	BUF	6
Camden-Gloucester, NJ	CDE	6
Conneaut, OH	CDY	6
Chicago, IL	CHI	6
Charleston, SC	CHS	6
Chester, PA	CHT	6
Cleveland, OH	CLE	6
Port Angeles, WA	CLM	6
Coos Bay, OR	COB	6
Corpus Christi, TX	CRP	6
Detroit, MI	DET	6
Duluth, MN	DLH	6
Drummond Island, MI	DRE	6
East Chicago, IN	ECH	6
Escanaba, MI	ESC	6
Fall River, MA	FAV	6
Fort Bragg, CA	FOB	6
Fourchon, LA	FOC	6
Freeport, TX	FPO	6
Fairport Harbor, OH	FPT	6
Grays Harbor, WA	GHC	6
Grand Haven, MI	GHN	6
Galveston, TX	GLS	6
Gulfport, MS	GPT	6
Green Bay, WI	GRB	6
Gulliver, MI	GUV	6
Gary, IN	GYG	6
Hempstead, NY	HEP	6
Honolulu, HI	HNL	6
Houston, TX	HOU	6
Hopewell, VA	HPW	6
New Haven, CT	HVN	6
Brunswick, GA	IDC	6
Wilmington, DE	ILG	6
Wilmington, NC	ILM	6
Ithaca, NY	ITH	6
Hilo, HI	ITO	6
Jacksonville, FL	JAX	6
Juneau, AK	JNU	6
Kalama, WA	KAM	6
Lakeside Marblehead, OH	KDB	6
Kinsman, IL	KFM	6

Region	Code	Band
Presque Isle, MI	PSS	5
Port Jefferson, NY	PTJ	5
Providence, RI	PVD	5
Portland, ME	PWM	5
Rhode Island	RI1	5
San Diego, CA	SAN	5
Savannah, GA	SAV	5
South Carolina 1	SC1	5
South Carolina 2	SC2	5
Seattle, WA	SEA	5
San Juan, PR	SIU	5
Brunswick, GA	SSI	5
Toledo, OH	TOL	5
Tampa, FL	TPA	5
Texas 1	TX1	5
Texas 2	TX2	5
Texas 3	TX3	5
Texas City, TX	TXT	5
Unalaska Island, AK	UAA	5
US Minor 1	UM1	5
US Minor 2	UM2	5
US Minor 3	UM3	5
US Minor 4	UM4	5
US Minor 5	UM5	5
US Minor 6	UM6	5
Virginia	VA1	5
Victoria, TX	VCT	5
Valdez, AK	VDZ	5
Virgin Islands	VI1	5
Vermont	VT1	5
Washington 1	WA1	5
Washington 2	WA2	5
Washington 3	WA3	5
Washington 4	WA4	5
Washington 5	WA5	5
Wisconsin 1	WI1	5
Wisconsin 2	WI2	5
Watkins Glen, NY	WKG	5
Yakutat, AK	YAK	5

Region	Code	Band
Marine City, MI	2TT	6
Albany, NY	ALB	6
Anchorage, AK	ANC	6
Alpena, MI	APN	6
New Iberia, LA	ARA	6
Ashtabula, OH	ASF	6
Baltimore, MD	BAL	6
Bridgeport, CT	BDR	6

Region	Code	Band
Portland, OR	PDX	6
Port Everglades, FL	PEF	6
Panama City, FL	PFN	6
Pascagoula, MS	PGL	6
Philadelphia, PA	PHL	6
Plaquemines, LA	PLQ	6
Pensacola, FL	PNS	6
Port Arthur, TX	POA	6
Ponce, PR	PSE	6
Portsmouth, NH	PSM	6
Presque Isle, MI	PSS	6
Port Jefferson, NY	PTJ	6
Providence, RI	PVD	6
Portland, ME	PWM	6
Richmond, CA	RCH	6
Redwood City, CA	RWC	6
San Diego, CA	SAN	6
Savannah, GA	SAV	6
Stockton, CA	SCK	6
St. Clair, MI	SCL	6
Sandusky, OH	SDW	6
Seattle, WA	SEA	6
San Francisco, CA	SFO	6
Silver Bay, MN	SIB	6
San Juan, PR	SJU	6
Two Harbors, MN	THB	6
Tacoma, WA	TIW	6
Toledo, OH	TOL	6
Tampa, FL	TPA	6
Texas City, TX	TXT	6
Unalaska Island, AK	UAA	6
Vancouver, WA	VAN	6
Victoria, TX	VCT	6
Valdez, AK	VDZ	6